

TURBOCHARGER PRECAUTION

TC00A-01

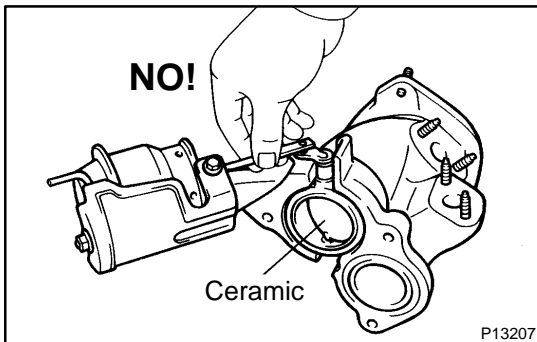

1. DO NOT STOP ENGINE IMMEDIATELY AFTER PULLING A TRAILER OR AFTER HIGH SPEED OR UPHILL DRIVING. IDLE ENGINE FOR 20 – 120 SECONDS, DEPENDING ON HOW HARD VEHICLE HAS BEEN DRIVEN
2. AVOID SUDDEN ACCELERATION OR RACING IMMEDIATELY AFTER STARTING A COLD ENGINE
3. DO NOT RUN ENGINE WITH AIR CLEANER REMOVED, AS THIS MAY CAUSE FOREIGN MATERIAL TO ENTER AND DAMAGE IMPELLER WHEEL OPERATING AT HIGH SPEED
4. IF A TURBOCHARGER IS FOUND TO BE DEFECTIVE AND MUST BE REPLACED, CHECK FOR CAUSE, AND REPAIR OR REPLACE FOLLOWING ITEMS AS NECESSARY
 - ◆ Engine oil level and quality
 - ◆ Conditions under which the turbocharger was used
 - ◆ Oil lines leading to the turbocharger
5. USE CAUTION WHEN REMOVING AND REINSTALLING TURBOCHARGER ASSEMBLY. DO NOT DROP IT OR KNOCK IT AGAINST ANYTHING OR GRASP IT BY EASILY-DEFORMED PARTS, SUCH AS ACTUATOR OR ROD, WHEN MOVING IT
6. USE CAUTION WHEN REMOVING AND REINSTALLING EXHAUST GAS CONTROL VALVE ASSEMBLY. DO NOT DROP IT OR KNOCK IT AGAINST ANYTHING OR GRASP IT BY EASILY-DEFORMED PARTS, SUCH AS ACTUATOR OR ROD, WHEN MOVING IT. CONTROL VALVE IS CERAMIC
7. BEFORE REMOVING TURBOCHARGER, PLUG INTAKE AND EXHAUST PORTS AND OIL INLET TO PREVENT ENTRY OF DIRT OR OTHER FOREIGN MATERIAL

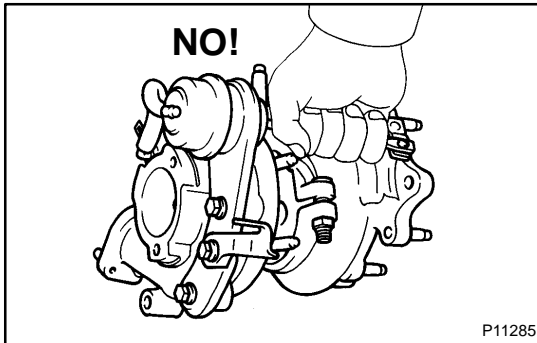
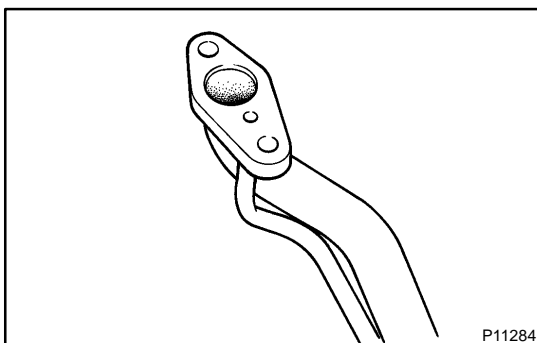

8. IF REPLACING TURBOCHARGER, CHECK FOR ACCUMULATION OF SLUDGE PARTICLES IN OIL PIPES, AND IF NECESSARY, REPLACE OIL PIPES
9. COMPLETELY REMOVE GASKET ADHERED TO LUBRICATION OIL PIPE FLANGE AND TURBOCHARGER OIL FLANGE
10. WHEN REPLACING BOLT OR NUTS, USE ONLY AUTHORIZED REPLACEMENT PARTS TO PREVENT BREAKAGE OR DEFORMATION

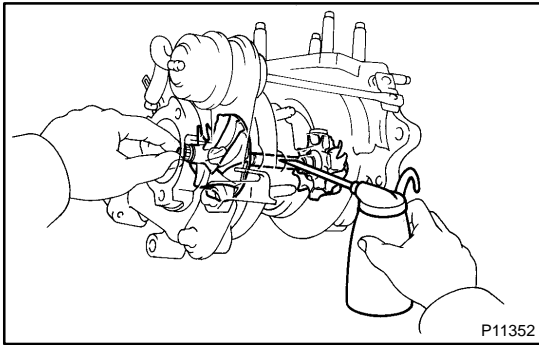

11. IF REPLACING TURBOCHARGER, POUR APPROX. 20 cm³ (1.2 cu in.) OF FRESH OIL INTO TURBOCHARGER OIL INLET AND TURN IMPELLER WHEEL BY HAND TO SPREAD OIL TO BEARING
12. IF OVERHAULING OR REPLACING ENGINE, CUT FUEL SUPPLY AFTER REASSEMBLY AND CRANK ENGINE FOR 30 SECONDS TO DISTRIBUTE OIL THROUGHOUT ENGINE. THEN ALLOW ENGINE TO IDLE FOR 60 SECONDS

TROUBLESHOOTING

HINT:

Before troubleshooting the turbocharger, first check the engine itself. (Valve clearance, engine compression, ignition timing etc.)

1. INSUFFICIENT ACCELERATION, LACK OF POWER OR EXCESSIVE FUEL CONSUMPTION

(Possible Cause)

(Check Procedure and Correction Method)

1. TURBOCHARGING PRESSURE TOO LOW

Check turbocharging pressure. (See page [TC-5](#))
Turbocharging pressure:
61 – 75 kPa
(0.62 – 0.76 kgf/cm², 8.8 – 10.8 psi)
 If the pressure is below specifications, begin diagnosis from item 2.

2. RESTRICTED INTAKE SYSTEM

Check intake air system, and repair or replace parts as necessary. (See page [TC-5](#))

3. LEAK IN INTAKE AIR SYSTEM

Check intake air system, and repair or replace parts as necessary. (See page [TC-5](#))

4. RESTRICTED EXHAUST SYSTEM

Check exhaust system, and repair or replace parts as necessary. (See page [TC-5](#))

5. LEAK IN EXHAUST SYSTEM

Check exhaust system, and repair or replace parts as necessary. (See page [TC-5](#))

6. ERRATIC TURBOCHARGER OPERATION

Check rotation of turbine shaft. If it does not turn or turns with a heavy drag, replace the turbocharger assembly.
 Check axial and radial play of turbine shaft. (See page [TC-18](#))
Maximum axial play : 0.110 mm (0.0045 in.)
Maximum radial play: 0.173 mm (0.0068 in.)
 If the play is greater than maximum, replace the turbocharger assembly.

2. ABNORMAL NOISE

(Possible cause)

1. TURBOCHARGING HEAT INSULATOR

(Check Procedure and Correction Method)

Check for loose, improperly installed or deformed insulator mounting bolts, and repair or replace as necessary.

2. EXHAUST PIPE LEAKING VIBRATING

Check for deformed exhaust pipe, loose mounting bolts or damaged gasket, and repair or replace as necessary.

3. ERRATIC TURBOCHARGER OPERATION

Refer to item 6 of INSUFFICIENT ACCELERATION, LACK OF POWER OR EXCESSIVE FUEL CONSUMPTION.

3. EXCESSIVE OIL CONSUMPTION OR WHITE EXHAUST

(Possible Cause)

FAULTY TURBOCHARGER SEAL

(Check Procedure and Correction Method)

Check for oil leakage in exhaust system
 ◆ Remove the turbine elbow from the turbocharger and check for excessive carbon deposits on the turbine wheel. Excessive carbon deposits indicate a faulty turbocharger.

Check for oil leakage in intake air system.

◆ Check for axial and radial play of turbine shaft and replace the turbocharger if necessary.
 (See page [TC-18](#))

Maximum axial play : 0.110 mm (0.0045 in.)
Maximum radial play : 0.173 mm (0.0068 in.)

NOTICE:

Some oil mist in the blowby from the PCV is normal.

Do not mistake it for an oil leak from the turbocharger.

ON-VEHICLE INSPECTION

1. INSPECT INTAKE AIR SYSTEM

Check for leakage or clogging between the air cleaner and turbocharger inlet and between the turbocharger outlet and cylinder head.

- ◆ Clogged air cleaner ..Clean or replace air filter
- ◆ Hoses collapsed or deformed Repair or replace
- ◆ Leakage from connections Check each connection and repair
- ◆ Cracks in components Check and replace

2. INSPECT EXHAUST SYSTEM

Check for leakage or clogging between the cylinder head and turbocharger inlet and between the turbocharger outlet and exhaust pipe.

- ◆ Deformed components Repair or replace
- ◆ Foreign material in passages Remove
- ◆ Leakage from components Repair or replace
- ◆ Cracks in components Check and replace

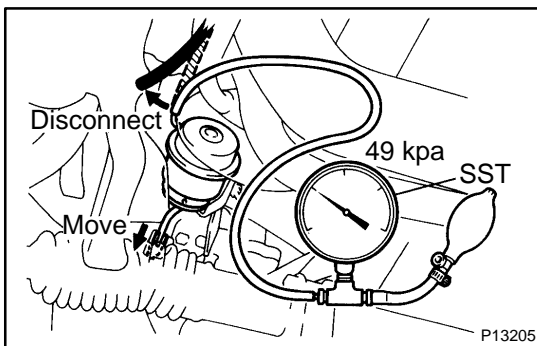

3. INSPECT EXHAUST GAS CONTROL VALVE OPERATION

- (a) Disconnect the air hose from the actuator.
- (b) Using SST, apply approx. 49 kPa (0.50 kgf/cm², 7.1 psi) of pressure to the actuator.
SST 09992-00242
- (c) Check that the actuator push rod moves.
- (d) Reconnect the air hose to the actuator.

If operation is not as specified, replace the control valve assembly.

4. INSPECT TURBOCHARGING PRESSURE

- (a) Using a 3-way connector, connect SST (turbocharger pressure gauge) to the hose between the gas filter and turbo pressure sensor.
SST 09992-00242
- (b) While driving with the engine running at 5,600 rpm or more with the throttle valve fully open in the 1st gear/L range, check the turbocharging pressure.

Standard pressure:

61 – 75 kPa (0.62 – 0.76 kgf/cm², 8.8 – 10.8 psi)

If the pressure is less than that specified, check the intake and exhaust systems for leakage. If there is no leakage, replace the turbocharger assembly.

If the pressure is above specification, check if the actuator hose is disconnected or cracked. If not, replace the turbocharger assembly.

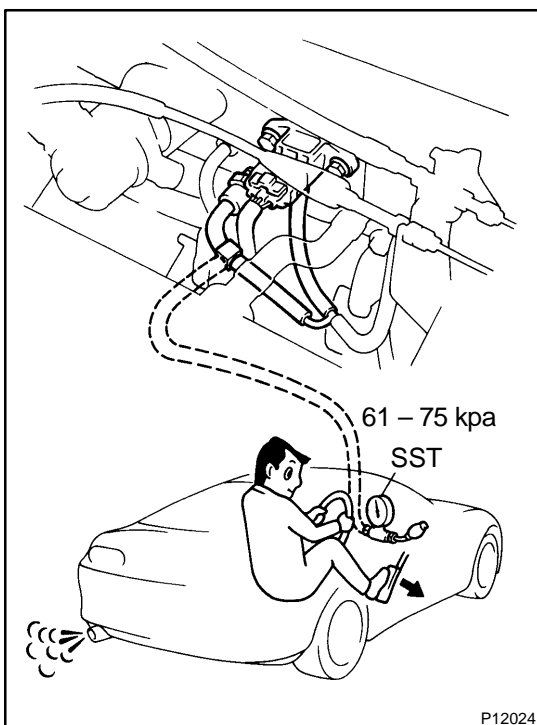

5. INSPECT VSV FOR INTAKE AIR CONTROL VALVE
(See page [SF-61](#))
6. INSPECT VSV FOR WASTE GATE VALVE
(See page [SF-63](#))
7. INSPECT VSV FOR EXHAUST GAS CONTROL VALVE
(See page [SF-65](#))
8. INSPECT VSV FOR EXHAUST BYPASS VALVE
(See page [SF-67](#))
9. INSPECT TURBO PRESSURE SENSOR
(See page [SF-79](#))

COMPONENTS

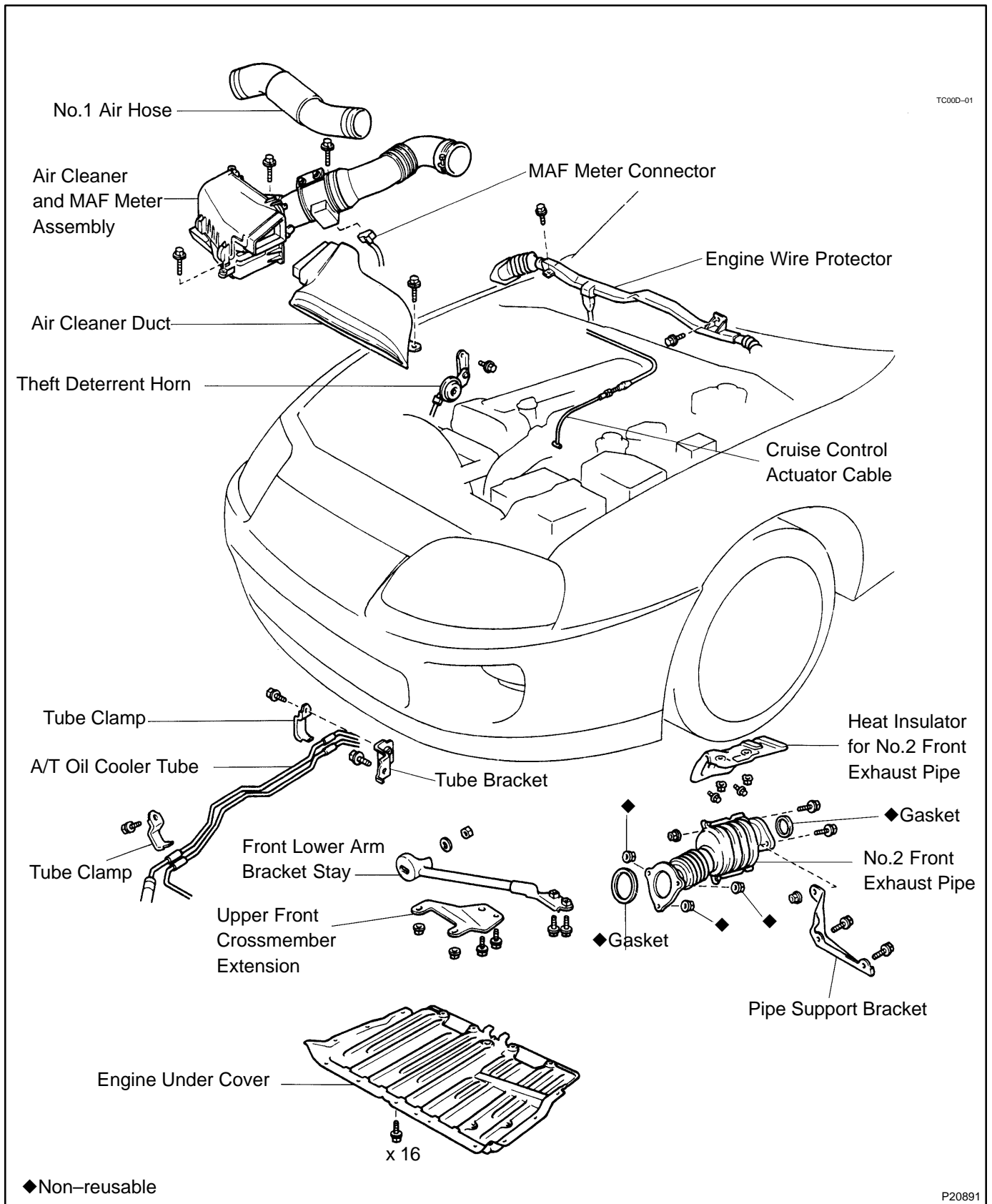

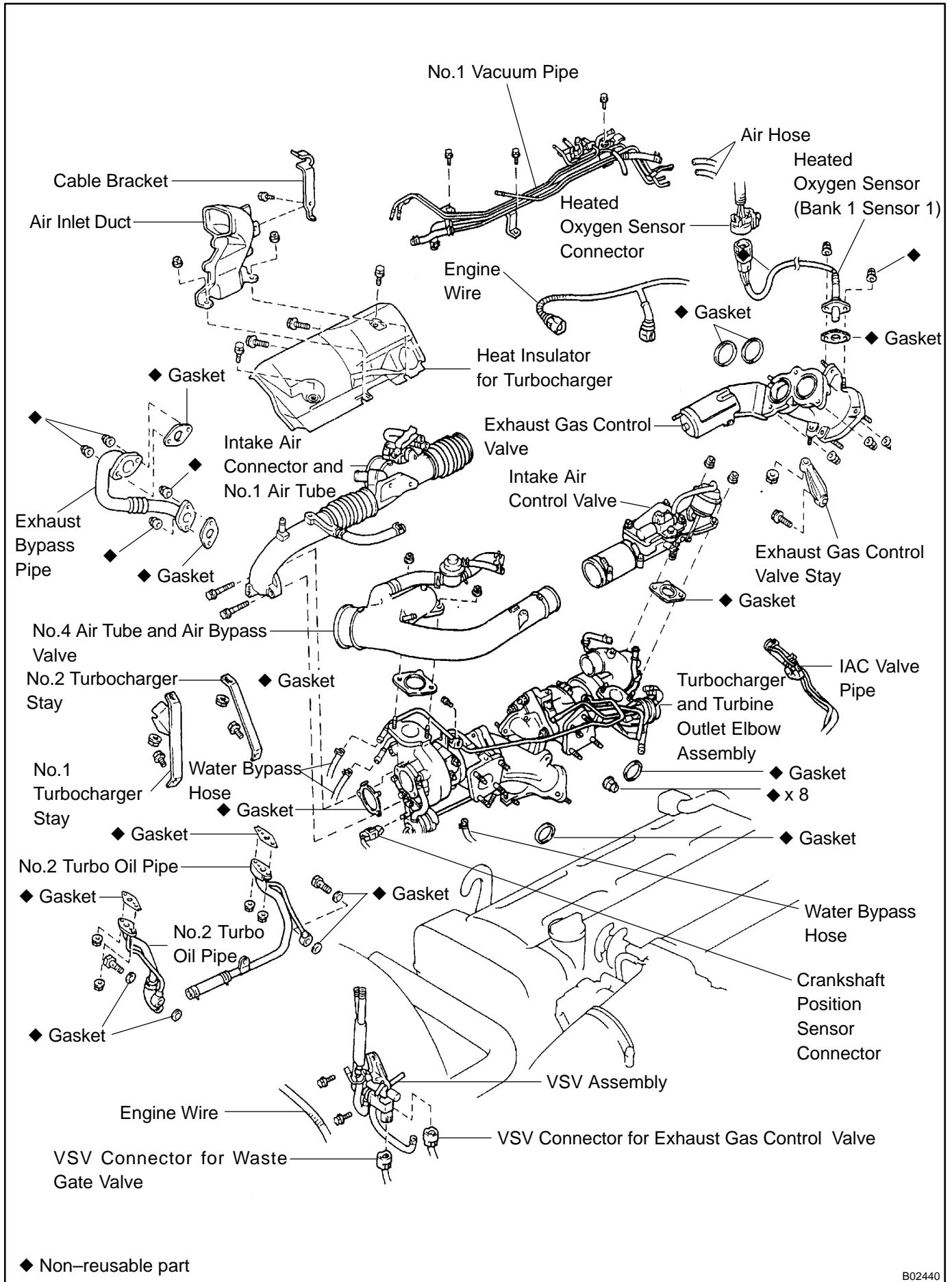

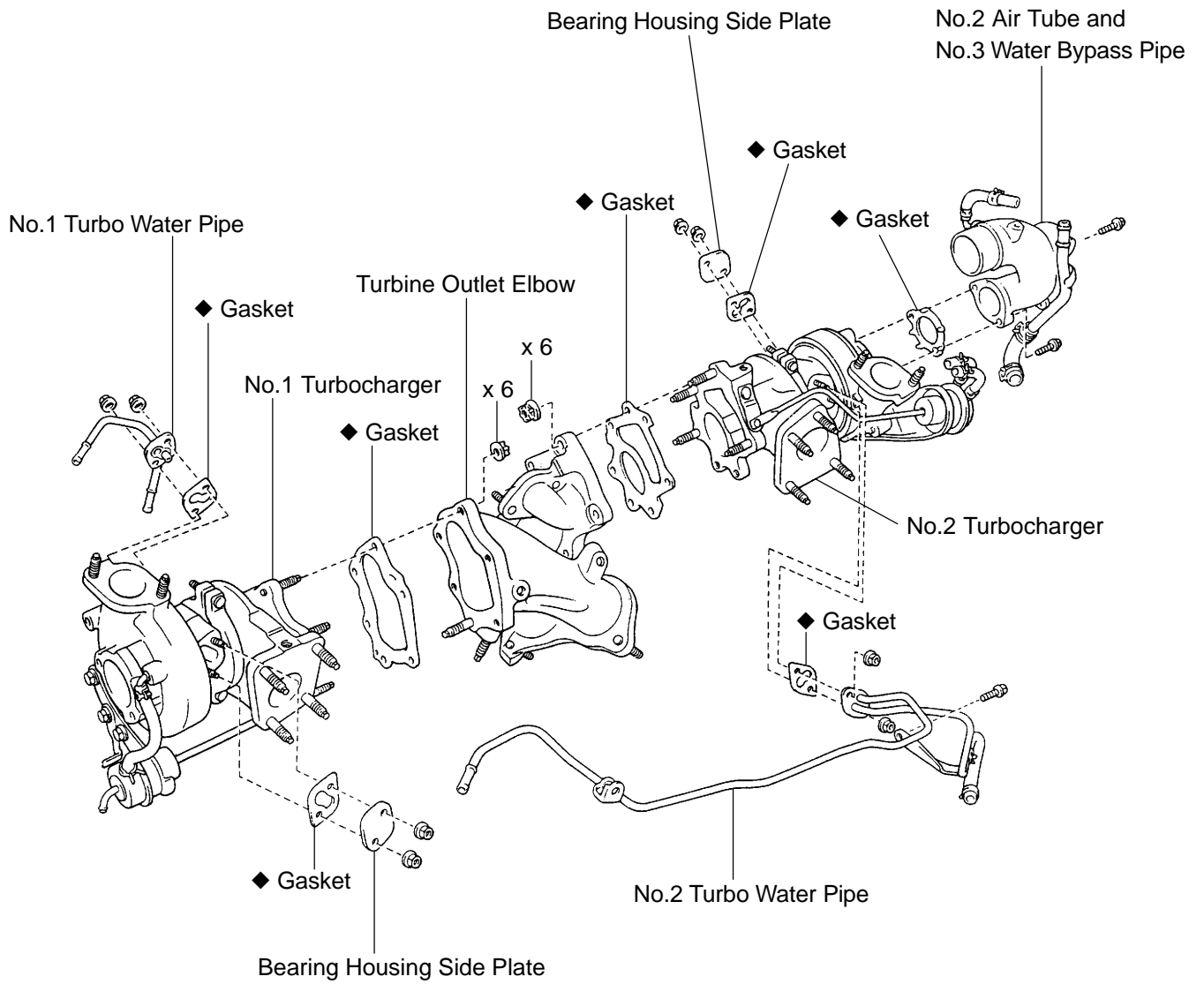

◆ Non-reusable part

REMOVAL

1. DRAIN ENGINE COOLANT
2. REMOVE ENGINE UNDER COVER
3. DISCONNECT CRUISE CONTROL ACTUATOR CABLE FROM THROTTLE BODY
4. REMOVE NO.1 AIR HOSE
5. REMOVE AIR CLEANER DUCT

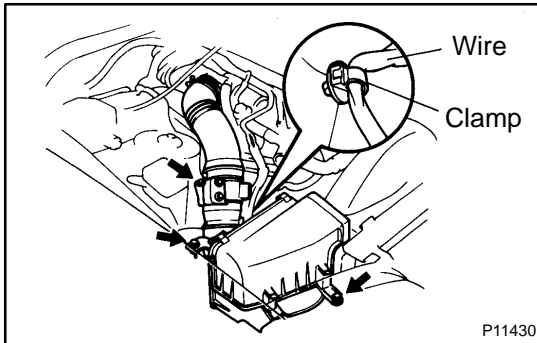

6. REMOVE AIR CLEANER AND MAF METER ASSEMBLY

- (a) Remove the 3 bolts.
- (b) Loosen the hose clamp, disconnect the air hose from the intake air connector.
- (c) Disconnect the MAF meter wire from the clamp on the air cleaner case.
- (d) Disconnect the MAF meter connector, and remove the air cleaner and MAF meter assembly.

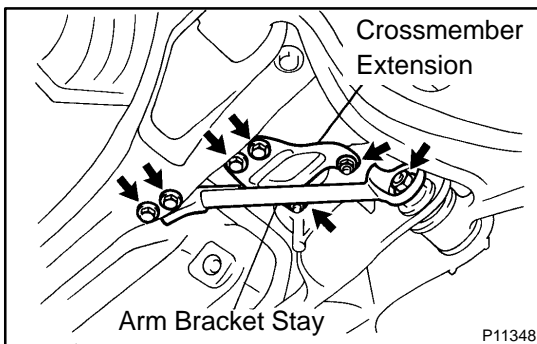

7. DISCONNECT THEFT DETERRENT HORN FROM BODY

8. REMOVE FRONT LOWER ARM BRACKET STAY

Remove the 2 bolts, nut, plate washer and arm bracket stay.

Torque:

Bolts 44 N·m (450 kgf·cm, 33 ft·lbf)

Nut 59 N·m (600 kgf·cm, 43 ft·lbf)

9. REMOVE UPPER FRONT CROSSMEMBER EXTENSION

Remove the 2 bolts, 2 nuts and crossmember extension.

Torque:

Bolts 29 N·m (300 kgf·cm, 22 ft·lbf)

Nuts 33 N·m (340 kgf·cm, 25 ft·lbf)

10. REMOVE NO.2 FRONT EXHAUST PIPE

- (a) Remove the 2 bolts and nuts holding the front exhaust pipe to the No.2 front exhaust pipe.

Torque: 58 N·m (590 kgf·cm, 43 ft·lbf)

- (b) Remove the 2 bolts and pipe support bracket.

Torque: 43 N·m (440 kgf·cm, 32 ft·lbf)

- (c) Disconnect the front exhaust pipe from the No.2 exhaust pipe. Remove the gasket.

HINT:

At the time of installation, please refer to the following items.
Use a new gasket.

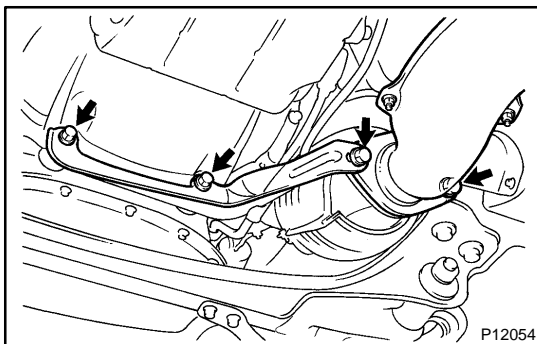

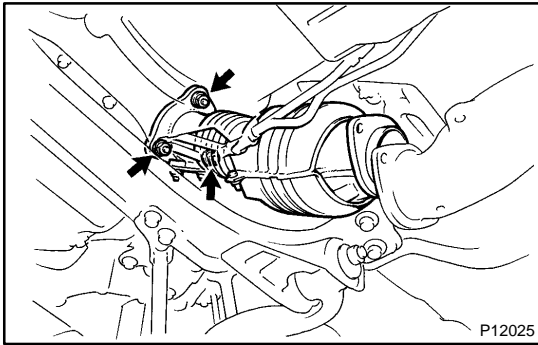

(d) Remove the 3 nuts, No.2 front exhaust pipe and gasket.
HINT:
 At the time of installation, please refer to the following items.
 Use a new gasket and 3 new nuts.

Torque: 62 N·m (630 kgf·cm, 46 ft·lbf)

11. REMOVE HEAT INSULATOR FOR NO.2 FRONT EXHAUST PIPE

Remove the 2 bolts, 2 nuts and heat insulator.

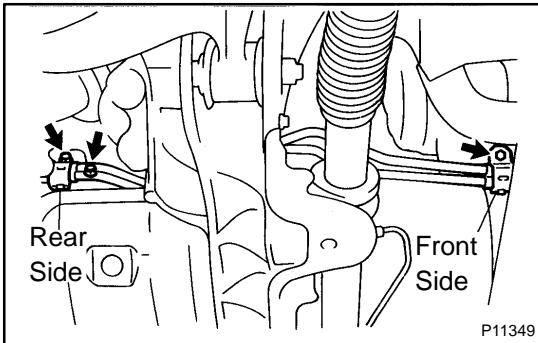

12. DISCONNECT A/T OIL COOLER TUBES FROM ENGINE

- (a) Remove the bolt and tube clamp, and disconnect the oil cooler tubes from the bracket (front side) on the generator.
- (b) Remove the bolt and tube clamp, and disconnect the oil cooler tubes from the bracket (rear side) on the cylinder block.
- (c) Remove the bolt and tube bracket (rear side) from the cylinder block.

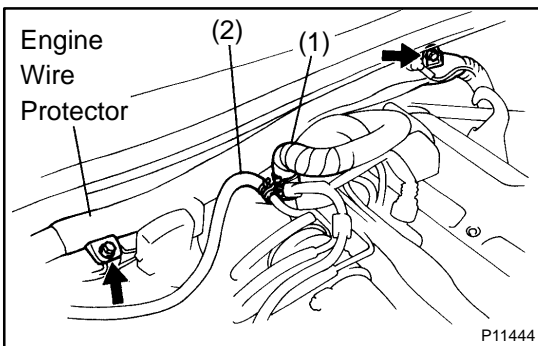

13. DISCONNECT ENGINE WIRE PROTECTOR FROM BODY

Remove the 2 bolts, and disconnect the wire protector from the body.

14. DISCONNECT HOSES

Disconnect these hoses:

- (1) Heater hose from No.3 water bypass pipe
- (2) EVAP hose from No.1 vacuum pipe

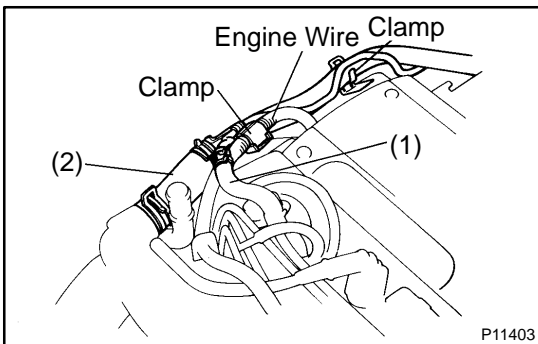

15. DISCONNECT IAC VALVE PIPE FROM NO.2 AIR TUBE

- (a) Disconnect the engine wire from the clamp.
- (b) Disconnect these hoses:
 - (1) Air hose (from No.1 vacuum pipe) from IAC valve pipe
 - (2) Air hose from No.2 air tube
- (c) Disconnect the IAC valve pipe from the clamp.

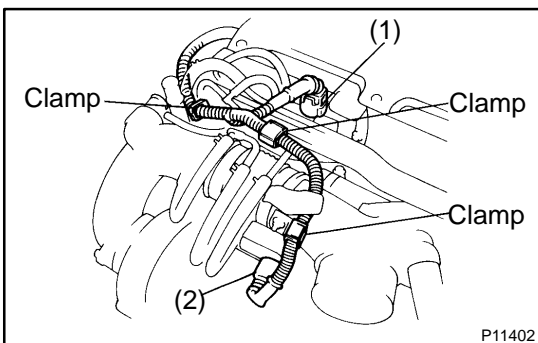

16. DISCONNECT NO.1 VACUUM PIPE FROM AIR TUBES

- (a) Disconnect these connectors:
 - (1) VSV connector for intake air control valve
 - (2) VSV connector for exhaust bypass valve
- (b) Disconnect the engine wire from the 3 clamps.

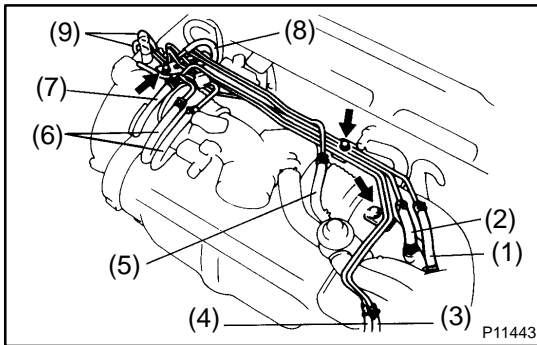

- (c) Disconnect these hoses:
- (1) Air hose from No.4 air tube
 - (2) Air hose from No.1 air tube
 - (3) Air hose (from VSV for waste gate valve) from vacuum pipe
 - (4) Air hose (from VSV for exhaust gas control valve) from vacuum pipe
 - (5) Vacuum hose (from air bypass valve) from No.1 air tube
 - (6) 2 air hoses (from VSV for exhaust bypass valve) from vacuum pipe
 - (7) Air hose (from No.2 air tube) from vacuum pipe
 - (8) Air hose from VSV for intake air control valve
 - (9) 2 air hoses (from pressure tank) from vacuum pipe
- (d) Remove the 3 bolts, and disconnect the vacuum pipe from the air tubes.

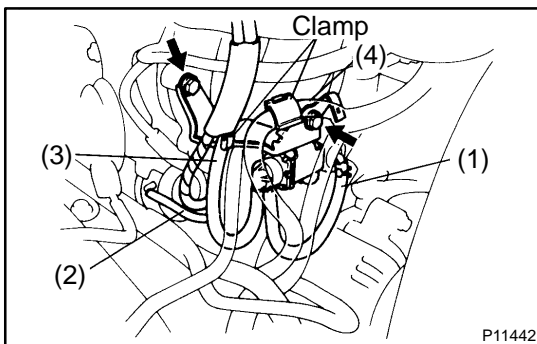

17. REMOVE VSV ASSEMBLY

- (a) Disconnect these hoses:
- (1) Air hose from actuator for waste gate valve
 - (2) Air hose from actuator for exhaust gas control valve
 - (3) Air hose from hose clamp
 - (4) Engine wire from wire clamp
- (b) Remove the 2 bolts.
- (c) Disconnect the 2 VSV connectors, and remove the VSV assembly.

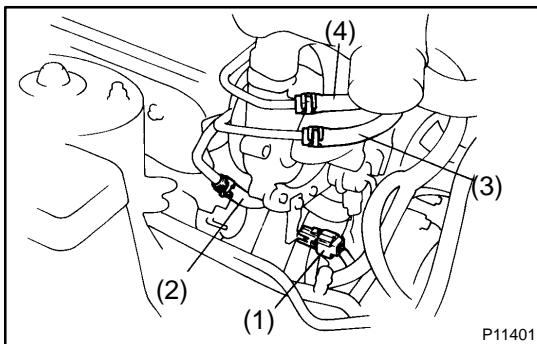

18. REMOVE AIR TUBES AND INTAKE AIR CONNECTOR

- (a) Disconnect the connector and hoses:
- (1) Crankshaft position sensor connector from clamp
 - (2) Water bypass hose (from water pump) from No.1 turbo water pipe
 - (3) Water bypass hose (from water outlet) from No.1 turbo water pipe
 - (4) Water bypass hose (from water outlet) from No.2 turbo water pipe
- (b) Remove the bolt, and disconnect the No.2 turbo water pipe from the No.4 air tube.

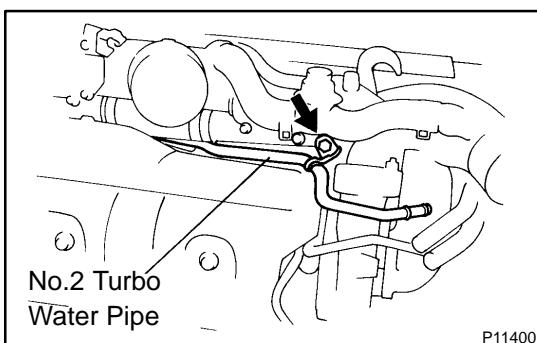

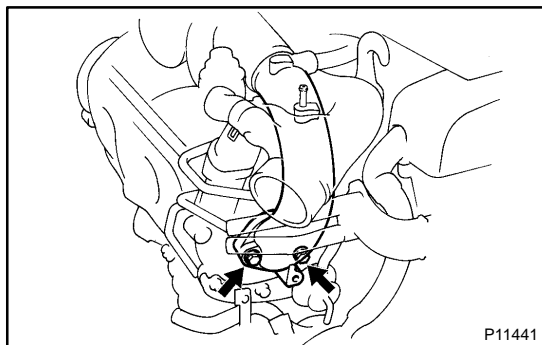

- (c) Remove the 2 bolts, and disconnect the No.1 air tube from the No.1 turbocharger. Remove the gasket.

HINT:

At the of installation, please refer to the following items.
Use a new gasket.

Torque: 21 N·m (210 kgf·cm, 15 ft·lbf)

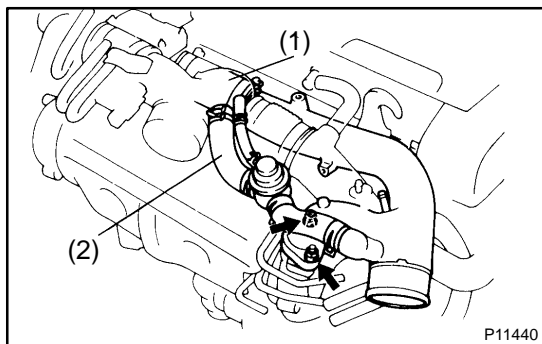

- (d) Remove the 2 bolts holding the No.4 air tube to the No.1 turbocharger. Remove the gasket.

HINT:

At the of installation, please refer to the following items.
Use a new gasket.

Torque: 21 N·m (210 kgf·cm, 15 ft·lbf)

- (e) Disconnect these hoses, and remove the No.4 air tube and air bypass valve assembly.

(1) Air hose from No.4 air tube

(2) Air hose from intake air connector

- (f) Remove the 2 nuts, intake air control valve and gasket.

HINT:

At the of installation, please refer to the following items.
Use a new gasket.

Torque: 21 N·m (210 kgf·cm, 15 ft·lbf)

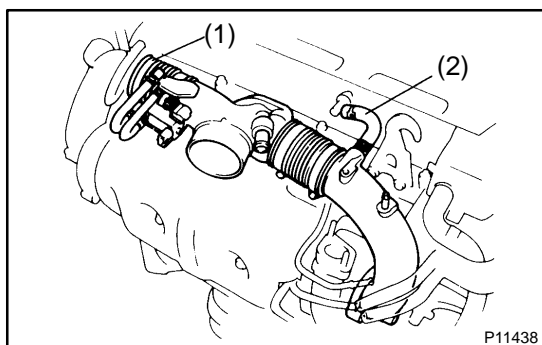
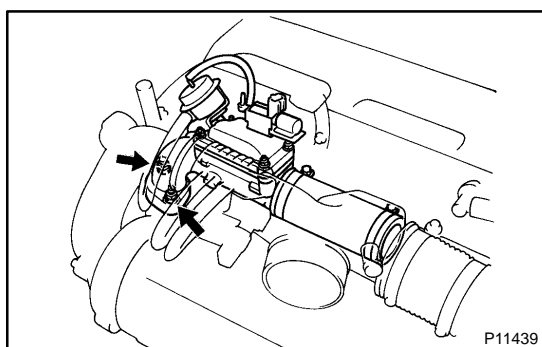

- (g) Disconnect these hoses, and remove the intake air connector and No.1 air tube assembly.

(1) Air hose from No.2 air tube

(2) PCV hose from No.2 cylinder head cover

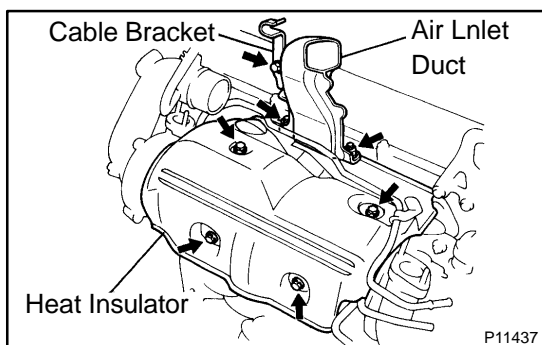

19. REMOVE AIR INLET DUCT

Remove the bolt, 2 nuts, cable bracket and air inlet duct.

20. REMOVE HEAT INSULATOR FOR TURBOCHARGER

Remove the 4 bolts and heat insulator.

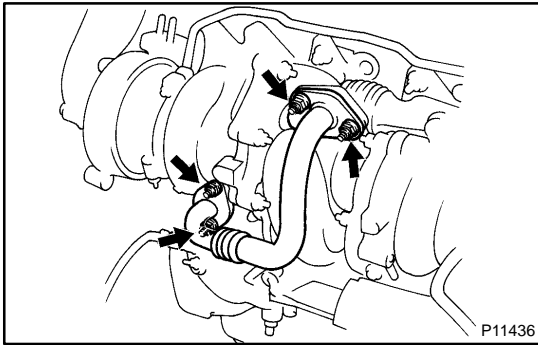
**21. REMOVE EXHAUST BYPASS PIPE**

Remove the 4 nuts, bypass pipe and 2 gaskets.

HINT:

At the time of installation, please refer to the following items.

Use 2 new gaskets and 4 new nuts.

Torque: 25 N·m (250 kgf·cm, 18 ft·lbf)

**22. REMOVE EXHAUST GAS CONTROL VALVE STAY**

Remove the bolt, nut and valve stay.

Torque: 44 N·m (440 kgf·cm, 32 ft·lbf)

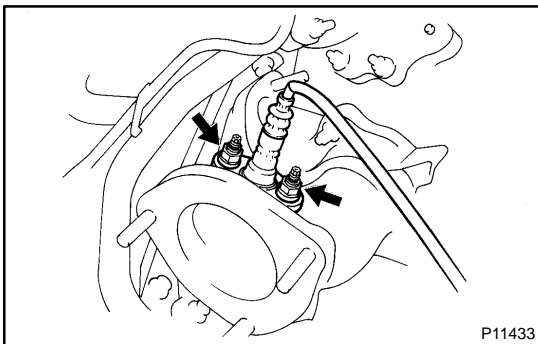
**23. REMOVE HEATED OXYGEN SENSOR**

(a) Disconnect the oxygen sensor connector.

(b) Remove the 2 nuts, oxygen sensor (bank 1 sensor 1) and gasket.

HINT:

At the time of installation, please refer to the following items.

Use a new gasket and 2 new nuts.

Torque: 20 N·m (200 kgf·cm, 14 ft·lbf)

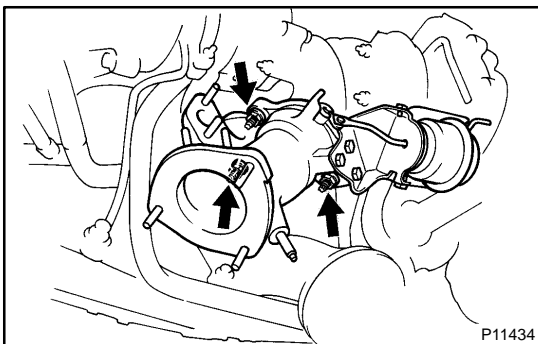
**24. REMOVE EXHAUST GAS CONTROL VALVE**

Remove the 3 nuts, control valve and 2 gaskets.

NOTICE:

The control valve is ceramic. Do not drop or knock the control valve.

HINT:

At the time of installation, please refer to the following items.

Use 2 new gaskets and 3 new nuts.

Torque: 70 N·m (700 kgf·cm, 52 ft·lbf)

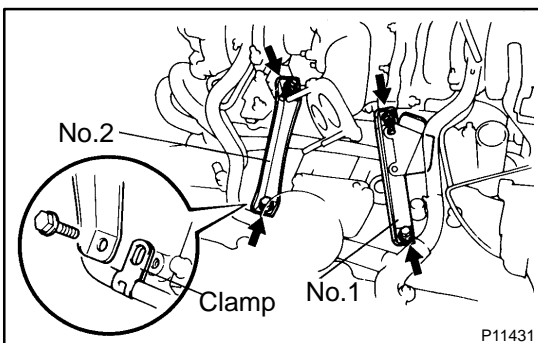
**25. REMOVE NO.1 TURBOCHARGER STAY**

Remove the bolt, nut and turbocharger stay.

Torque: 44 N·m (440 kgf·cm, 32 ft·lbf)

26. REMOVE NO.2 TURBOCHARGER STAY

Remove the bolt, nut and turbocharger stay.

HINT:

At the time of installation, please refer to the following items.

Install the turbocharger stay and No.1 turbo oil pipe clamp with the bolt and nut.

Torque: 44 N·m (440 kgf·cm, 32 ft·lbf)

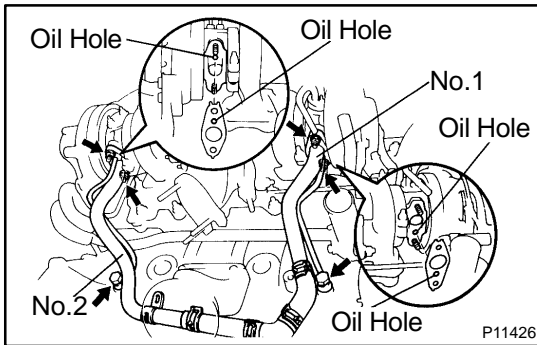
**27. REMOVE NO.1 TURBO OIL PIPE**

- (a) Remove the union bolt holding the turbo oil pipe to the cylinder block. Remove the 2 gaskets.

HINT:

At the time of installation, please refer to the following items.
Use 2 new gaskets.

Torque: 45 N·m (450 kgf-cm, 33 ft-lbf)

- (b) Remove the 2 nuts, and disconnect the turbo oil pipe from turbocharger. Remove the gasket.

HINT:

- ◆ At the time of installation, please refer to the following items.
- ◆ Use a new gasket.
- ◆ Align the oil holes of the gasket and turbocharger housing.

Torque: 21 N·m (210 kgf-cm, 15 ft-lbf)

- (c) Disconnect the turbo oil hose from the turbo oil outlet on the No.1 oil pan, and remove the turbo oil pipe.

28. REMOVE NO.2 TURBO OIL PIPE

- (a) Remove the union bolt holding the turbo oil pipe to the cylinder block. Remove the 2 gaskets.

HINT:

At the time of installation, please refer to the following items.
Use 2 new gaskets.

Torque: 45 N·m (450 kgf-cm, 33 ft-lbf)

- (b) Remove the 2 nuts, and disconnect the turbo oil pipe from turbocharger. Remove the gasket.

HINT:

- ◆ At the time of installation, please refer to the following items.
- ◆ Use a new gasket.
- ◆ Align the oil holes of the gasket and turbocharger housing.

Torque: 21 N·m (210 kgf-cm, 15 ft-lbf)

- (c) Disconnect the turbo oil hose from the turbo oil outlet on the No.1 oil pan, and remove the turbo oil pipe.

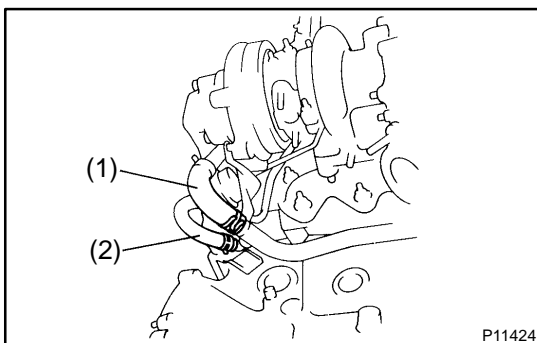
**29. REMOVE TURBOCHARGERS AND TURBINE OUTLET ELBOW ASSEMBLY**

- (a) Disconnect these hoses:
- (1) Heater hose (from No.3 water bypass pipe) from No.2 water bypass pipe
 - (2) Water bypass hose (from No.2 turbo water pipe) from No.2 water bypass pipe

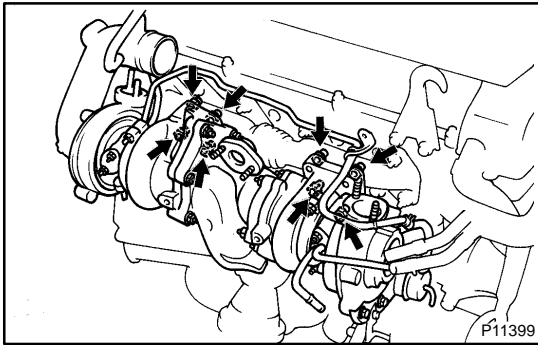

- (b) Remove the 8 nuts holding the turbochargers to the exhaust manifold.

HINT:

- ◆ At the time of installation, please refer to the following items.
- ◆ Use 8 new nuts.
- ◆ Uniformly tighten the nuts in several passes.

Torque: 55 N·m (550 kgf-cm, 41 ft-lbf)

- (c) Remove the 2 turbochargers and turbine outlet elbow assembly.

- (d) Remove the 2 gaskets.

HINT:

At the time of installation, please refer to the following items.
Use 2 new gaskets.

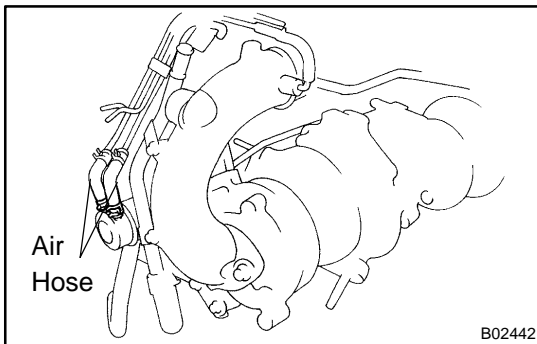

30. REMOVE NO.1 VACUUM PIPE FROM NO.2 TURBOCHARGER

Disconnect the 2 air hoses from the actuator for the exhaust bypass valve, and remove the vacuum pipe.

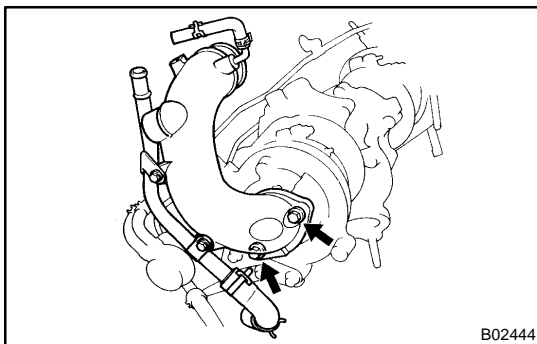

31. REMOVE NO.2 AIR TUBE AND NO.3 WATER BYPASS PIPE ASSEMBLY FROM NO.2 TURBOCHARGER

Remove the 2 bolts, the air tube, bypass pipe assembly and gasket.

HINT:

At the time of installation, please refer to the following items.
Use a new gasket.

Torque: 21 N·m (210 kgf-cm, 15 ft-lbf)

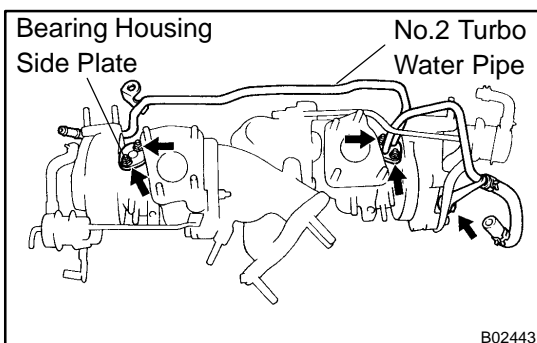

32. REMOVE NO.2 TURBO WATER PIPE FROM NO.2 TURBOCHARGER

Remove the 2 nuts, water pipe and gasket.

HINT:

At the time of installation, please refer to the following items.
Use a new gasket.

Torque: 9.0 N·m (90 kgf-cm, 80 in.-lbf)

33. REMOVE BEARING HOUSING SIDE PLATE FROM NO.1 TURBOCHARGER

Remove the 2 nuts, housing plate and gasket.

HINT:

At the time of installation, please refer to the following items.
Use a new gasket.

Torque: 9.0 N·m (90 kgf·cm, 80 in.-lbf)

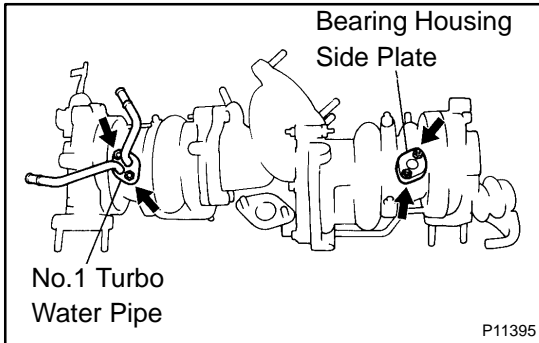

34. REMOVE NO.1 TURBO WATER PIPE FROM NO.1 TURBOCHARGER

Remove the 2 nuts, water pipe and gasket.

HINT:

At the time of installation, please refer to the following items.
Use a new gasket.

Torque: 9.0 N·m (90 kgf·cm, 80 in.-lbf)

35. REMOVE BEARING HOUSING SIDE PLATE FROM NO.2 TURBOCHARGER

Remove the 2 nuts, housing plate and gasket.

HINT:

At the time of installation, please refer to the following items.
Use a new gasket.

Torque: 9.0 N·m (90 kgf·cm, 80 in.-lbf)

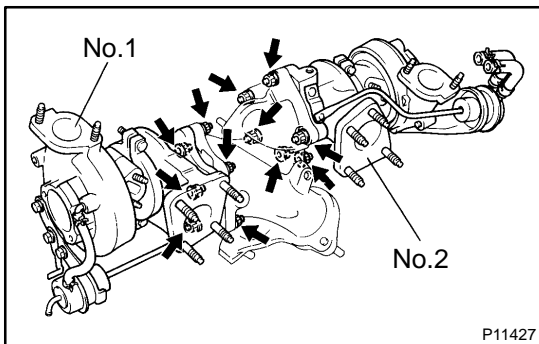

36. REMOVE NO.1 TURBOCHARGER FROM TURBINE OUTLET ELBOW

Remove the 6 nuts, turbocharger and gasket.

HINT:

- ◆ At the time of installation, please refer to the following items.
- ◆ Use a new gasket and 6 new nuts.
- ◆ Uniformly tighten the nuts in several passes.

Torque: 25 N·m (250 kgf·cm, 18 ft-lbf)

37. REMOVE NO.2 TURBOCHARGER FROM TURBINE OUTLET ELBOW

Remove the 6 nuts, turbocharger and gasket.

HINT:

- ◆ At the time of installation, please refer to the following items.
- ◆ Use a new gasket and 6 new nuts.
- ◆ Uniformly tighten the nuts in several passes.

Torque: 25 N·m (250 kgf·cm, 18 ft-lbf)

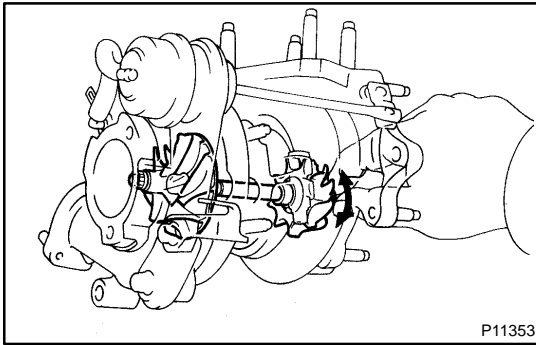

INSPECTION

1. INSPECT TURBINE SHAFT ROTATION

Grasp the edge of the turbine wheel and turn it. Check that the impeller wheel turns smoothly.

If the impeller wheel does not turn or if it turns with a drag, replace the turbocharger assembly.

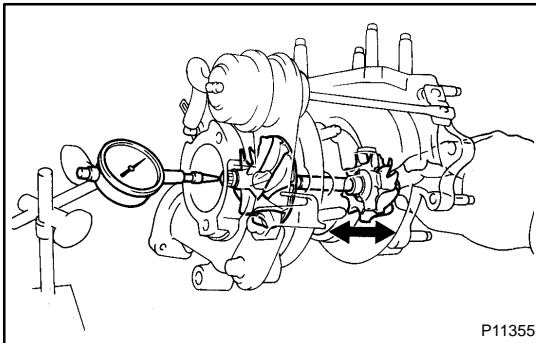

2. INSPECT AXIAL PLAY OF TURBINE SHAFT

(a) Using a dial indicator, insert the needle of the dial indicator into the air tube side.

(b) Move the turbine shaft in an axial direction, measure the axial play of the turbine shaft.

Maximum axial play:

0.110 mm (0.0045 in.)

If the axial play is greater than maximum, replace the turbocharger assembly.

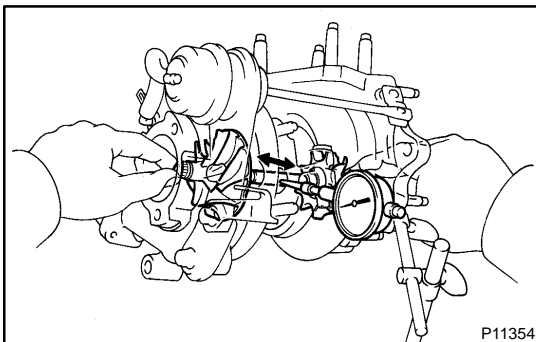

3. INSPECT RADIAL PLAY OF TURBINE SHAFT

(a) Using a dial indicator, insert the needle of the dial indicator into the oil outlet hole and set it in the center of the turbine shaft.

(b) Move the turbine shaft in a radial direction, measure the radial play of the turbine shaft.

Maximum radial play:

0.173 mm (0.0068 in.)

If the axial play is greater than maximum, replace the turbocharger assembly.

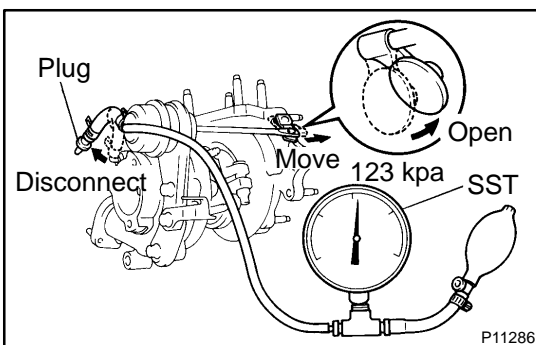

4. INSPECT WASTE GATE VALVE OPERATION

(a) Disconnect the actuator air hose from the housing, and plug the hose end.

(b) Using SST, apply approx. 123 kPa (1.25 kgf/cm², 17.8 psi) of pressure to the actuator.

SST 09992-00242

(c) Move the actuator push rod, and check that the waste gate valve is open.

If operation is not as specified, replace the No.1 turbocharger assembly.

NOTICE:

Never apply more than 136.7 kPa (1.39 kgf/cm², 19.8 psi) of pressure to the actuator.

(d) Reconnect the actuator air hose to the housing.

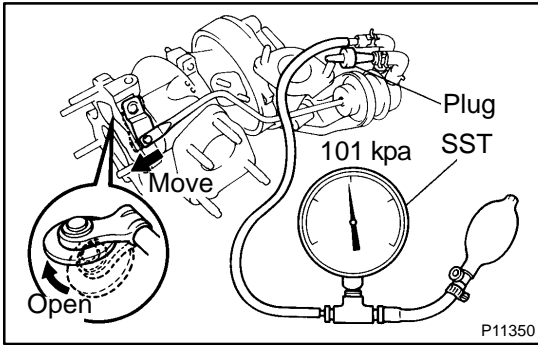

5. INSPECT EXHAUST BYPASS VALVE OPERATION

- (a) Plug one side of the actuator air hose end.
- (b) Using SST, apply approx. 101 kPa (1.03 kgf/cm², 14.7 psi) of pressure to the actuator.
SST 09992 – 00242
- (c) Move the actuator push rod, and check that the exhaust bypass valve is open.

If operation is not as specified, replace the No.2 turbocharger assembly.

NOTICE:

Never apply more than 114.7 kPa (1.17 kgf/cm², 16.6 psi) of pressure to the actuator.

- (d) Remove the plug from the actuator air hose end.

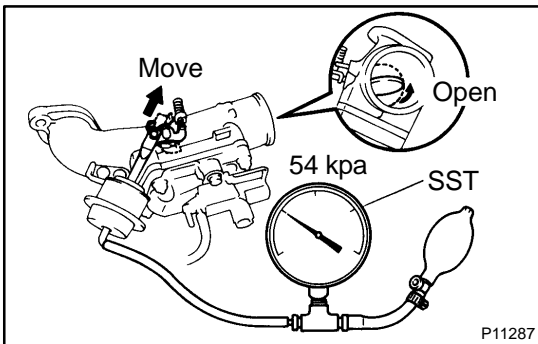

6. INSPECT INTAKE AIR CONTROL VALVE OPERATION

- (a) Using SST, apply approx. 54 kPa (0.55 kgf/cm², 7.8 psi) of pressure to the actuator.
SST 09992-00242
- (b) Move the actuator push rod, and check that the control valve is open.

If operation is not as specified, replace the control valve assembly.

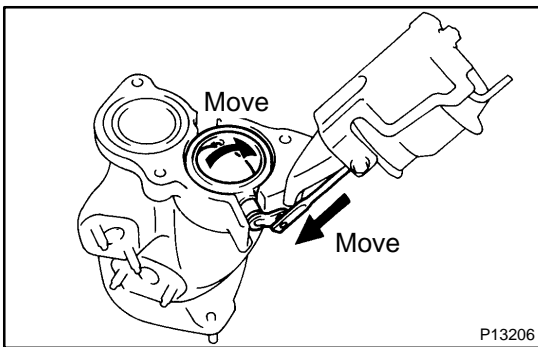

7. INSPECT EXHAUST GAS CONTROL VALVE FOR DAMAGE

Move the actuator push rod and control valve, and check the control valve for damage.

If the valve is damaged, replace the control valve assembly.

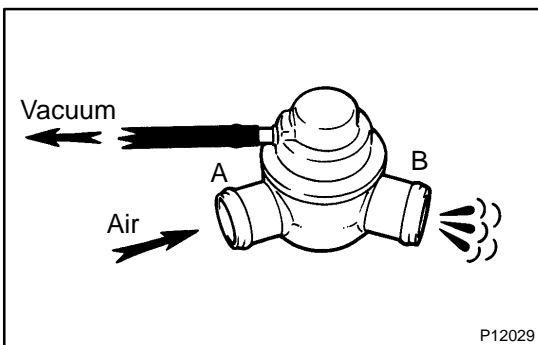

8. INSPECT AIR BYPASS VALVE OPERATION

- (a) Check that air does not flow from port A to B.
- (b) Apply vacuum to the actuator.
- (c) Check that air flows from port A to B.

If operation is not as specified, replace the valve.

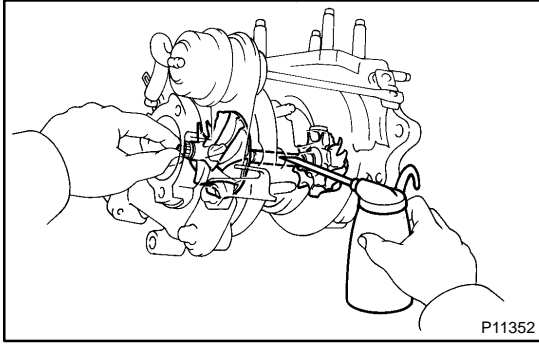

INSTALLATION

Installation is in the reverse order of removal.

(See page [TC-10](#))

NOTICE:

After replacing the turbocharger assembly, pour approx. 20 cm³ (1.2 cu in.) of fresh oil into the oil inlet hole and turn the turbine wheel by hand to splash oil on the bearing.

PRESSURE TANK COMPONENTS

TC00H-01

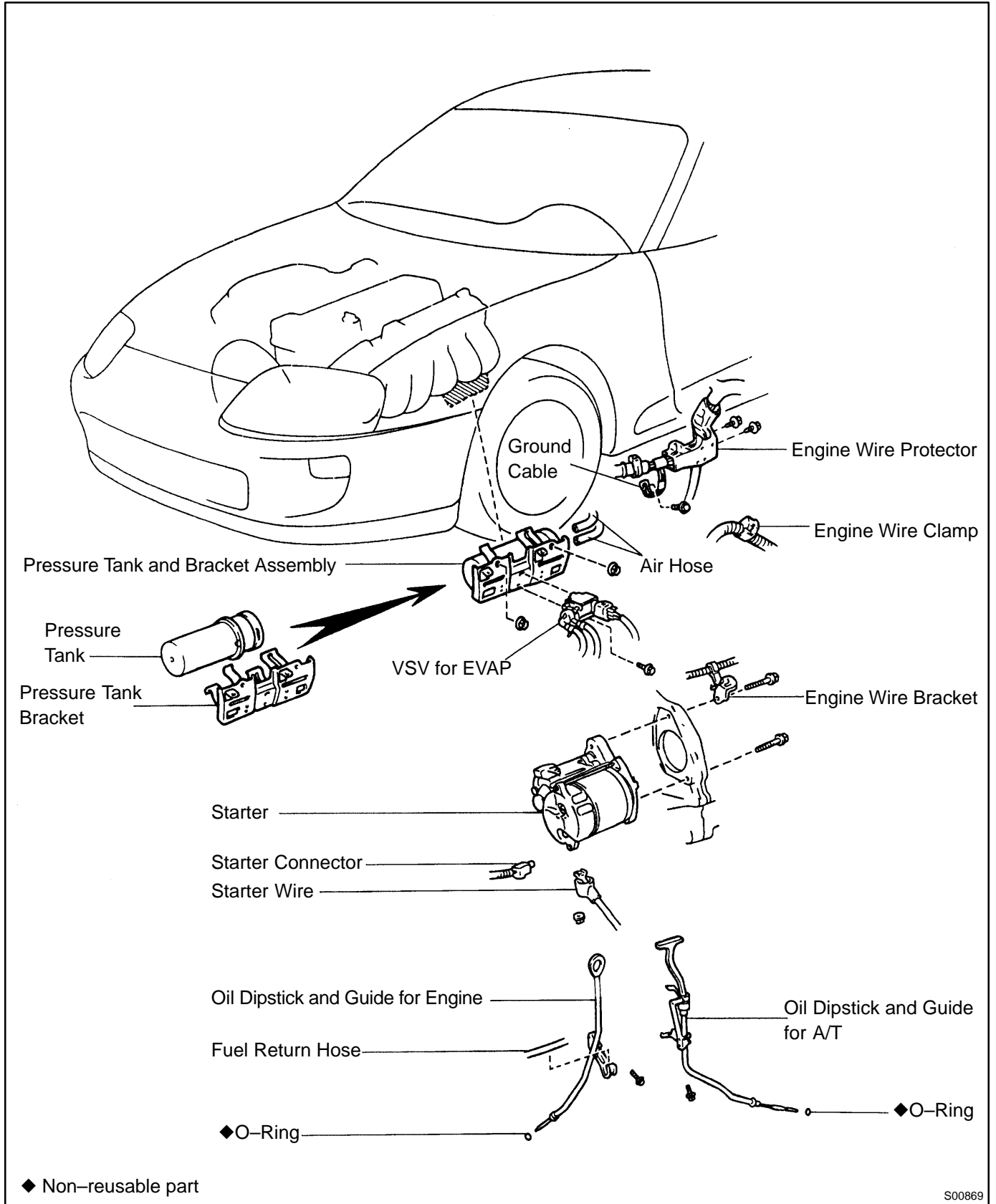

S00869

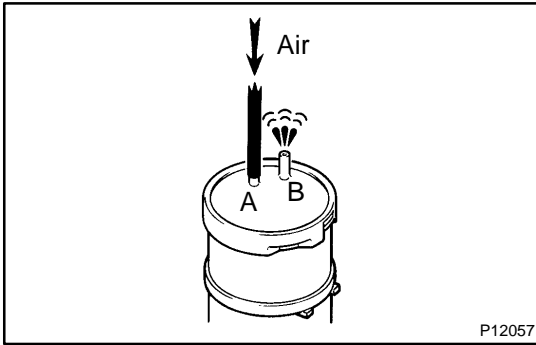

INSPECTION

1. REMOVE PRESSURE TANK

2. INSPECT PRESSURE TANK

(a) Check that air flows from port A to B.

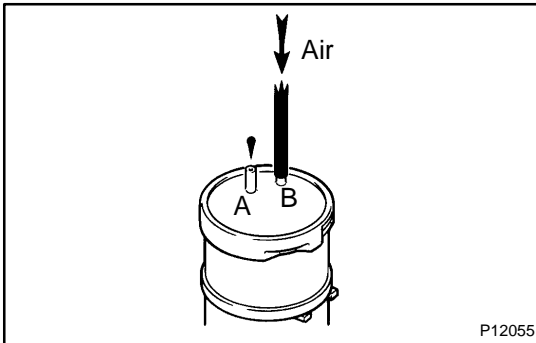

(b) Check that air does not flow from port B to A.

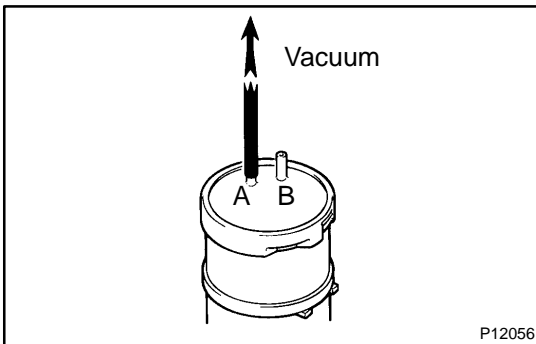

(c) Apply 60.0 kPa (450 mmHg, 17.72 in.Hg) of vacuum to port A, and check that there is no change in vacuum after 1 minute.

If operation is not as specified, replace the pressure tank.

3. REINSTALL PRESSURE TANK

CHARGE AIR COOLER (CAC) COMPONENTS

TC00J-01

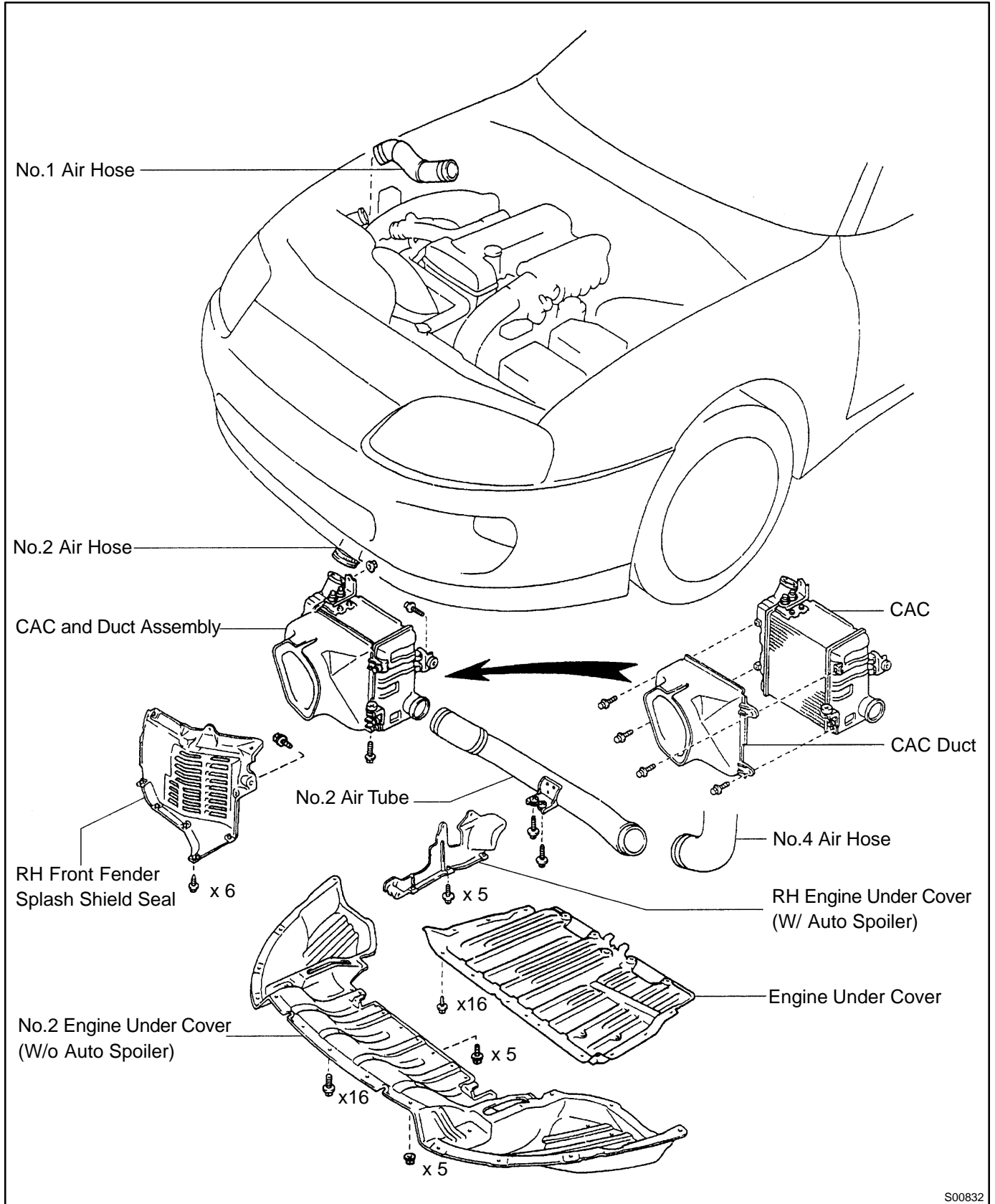

REMOVAL

1. REMOVE NO.1 AIR HOSE
2. REMOVE ENGINE UNDER COVER
3. **w/o Auto Spoiler:**
REMOVE NO.2 ENGINE UNDER COVER
4. REMOVE RH FRONT FENDER SPLASH SHIELD SEAL
5. **w/ Auto Spoiler:**
REMOVE RH ENGINE UNDER COVER
6. **DISCONNECT AIR HOSE FROM CAC**
 - (a) Remove the 2 bolts holding the No.2 air tube (4) to the body.
 - (b) Disconnect these hoses:
 - (1) No.2 air hose from CAC
 - (2) No.4 air hose from No.2 air tube
 - (3) No.3 air hose from CAC
 - (c) Remove the No.2 air tube (4).

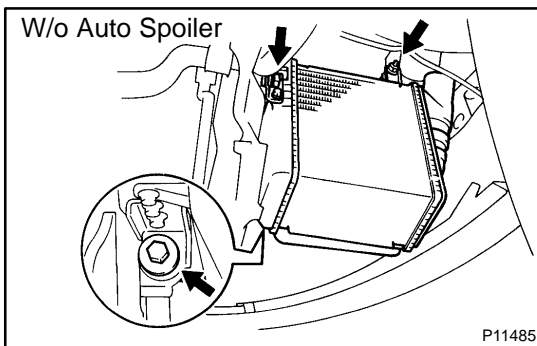
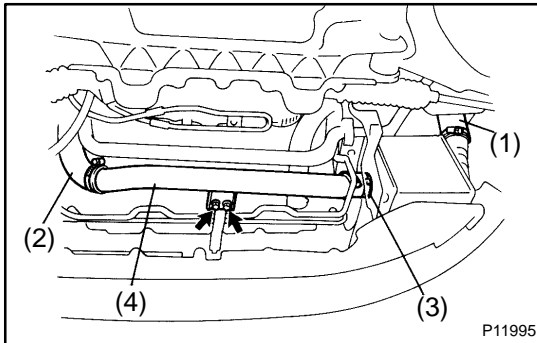

7. **W/o Auto Spoiler:**
REMOVE CAC AND CAC DUCT ASSEMBLY

Remove the nut, 2 bolts and CAC.

Torque: 13 N·m (135 kgf·cm, 10 ft·lbf)

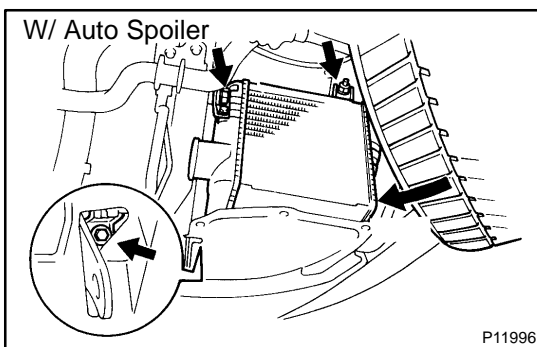

8. **W/ Auto Spoiler:**

- (a) Fully turn the tire in the illustration direction.
- (b) Remove the nut, 2 bolts and CAC.

Torque: 13 N·m (135 kgf·cm, 10 ft·lbf)

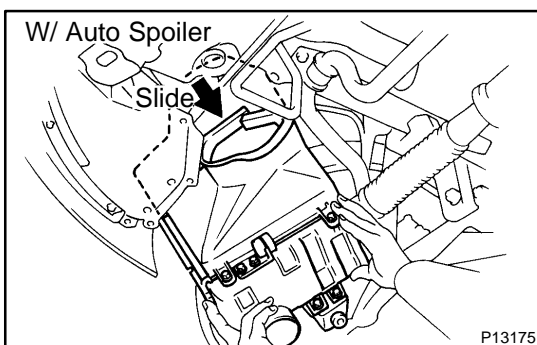

HINT:

Remove the CAC between the suspension and body at the illustrated angle of the CAC.

9. **REMOVE CAC DUCT FROM CAC**

Remove the 4 bolts and CAC duct.

Torque: 4.9 N·m (50 kgf·cm, 43 in·lbf)

INSTALLATION

Installation is in the reverse order of removal (See page [TC-24](#)).