

SRS AIRBAG

PRECAUTION

RS08L-01

NOTICE:

- The SUPRA is equipped with SRS, which comprises a driver airbag, front passenger airbag. Failure to carry out service operations in the correct sequence could cause the SRS to unexpectedly deploy during servicing, possibly leading to a serious accident. Further, if a mistake is made in servicing the SRS, it is possible that the SRS may fail to operate when required. Before performing servicing (including removal or installation of parts, inspection or replacement), be sure to read the following items carefully, then follow the correct procedures described in the repair manual.
- Malfunction symptoms of the SRS are difficult to confirm, so the DTCs become the most important source of information when troubleshooting. When troubleshooting the SRS, always inspect the DTCs before disconnecting the battery.
- Even in cases of a minor collision where the SRS does not deploy, the steering wheel pad, front passenger airbag assembly and airbag sensor assembly should be inspected (See page [RS-11](#), [RS-25](#) and [RS-38](#)).
- Never use SRS parts from another vehicle. When replacing parts, replace them with new parts.
- Never disassemble and repair the steering wheel pad, front passenger airbag assembly or airbag sensor assembly in order to reuse it.
- If the steering wheel pad, front passenger airbag assembly or airbag sensor assembly has been dropped, or if there are cracks, dents or other defects in the case, bracket or connector, replace them with new ones.
- Use a volt/ohmmeter with high impedance (10 k Ω /V minimum) for troubleshooting the system's electrical circuits.
- Information labels are attached to the periphery of the SRS components. Follow the instructions on the notices.
- After work on the SRS is completed, perform the SRS warning light check (See page [DI-589](#)).
- If the vehicle is equipped with a mobile communication system, refer to the precaution in the IN section.

CAUTION:

- Work must be started after 90 seconds from when the ignition switch is turned to the "LOCK" position and the negative (-) terminal cable is disconnected from the battery. (The SRS is equipped with a back-up power source so that if work is started within 90 seconds from disconnecting the negative (-) terminal cable of the battery, the SRS may be deployed.)
- When the negative (-) terminal cable is disconnected from the battery, the memory of the clock and audio system will be canceled. So before starting work, make a record of the contents memorized in the audio memory system. When work is finished, reset the audio systems as they were before and adjust the clock. To avoid erasing the memory in each memory system, never use a back-up power supply from outside the vehicle.
- Before repairs, remove the airbag sensor if shocks are likely to be applied to the sensor during repairs.
- Do not expose the steering wheel pad, front passenger airbag assembly or airbag sensor assembly directly to hot air or flames.

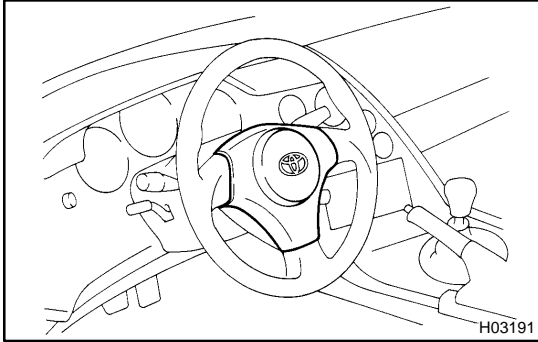

OPERATION

1. STEERING WHEEL PAD (with AIRBAG)

The inflator and bag of the SRS are stored in the steering wheel pad and cannot be disassembled. The inflator contains a squib, igniter charge, gas generant, etc., and inflates the bag when instructed by the airbag sensor assembly.

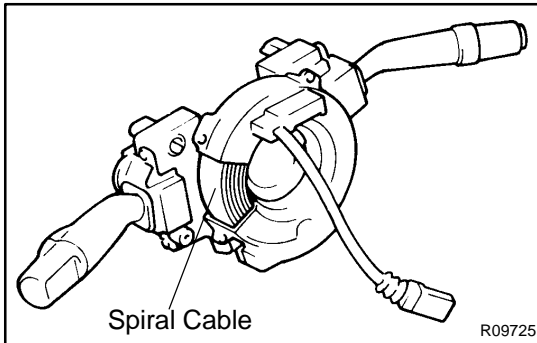

2. SPIRAL CABLE (in COMBINATION SWITCH)

A spiral cable is used as an electrical joint from the vehicle body side to the steering wheel.

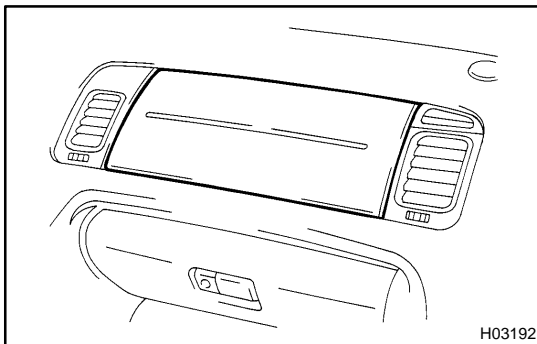

3. FRONT PASSENGER AIRBAG ASSEMBLY

The inflator and bag of the SRS are stored in the front passenger airbag assembly and cannot be disassembled. The inflator contains a squib, igniter charge and gas generant, etc., and inflates the bag when instructed by the airbag sensor assembly.

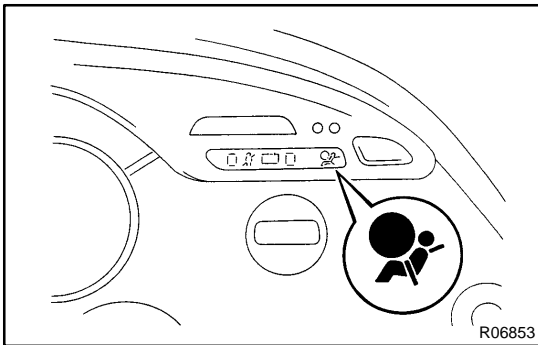

4. SRS WARNING LIGHT

The SRS warning light is located on the combination meter. It goes on to alert the driver of trouble in the system when a malfunction is detected in the airbag sensor assembly. In normal operation conditions when the ignition switch is turned to the ACC or ON position, the light goes on for about 6 seconds and then goes off.

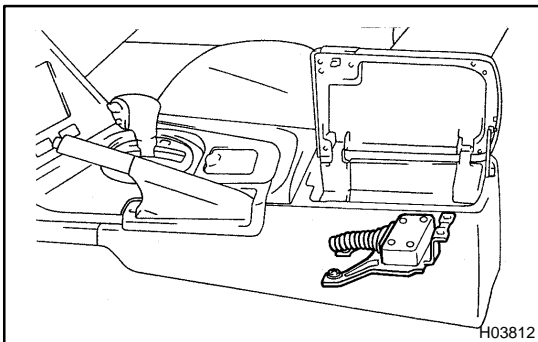

5. AIRBAG SENSOR ASSEMBLY

The airbag sensor assembly is mounted on the floor inside the lower center finish panel. The airbag sensor assembly consists of an airbag sensor, safing sensor, diagnosis circuit and ignition control, drive circuit, etc. It receives signals from the airbag sensor and judges whether the SRS must be activated or not.

6. SRS CONNECTORS

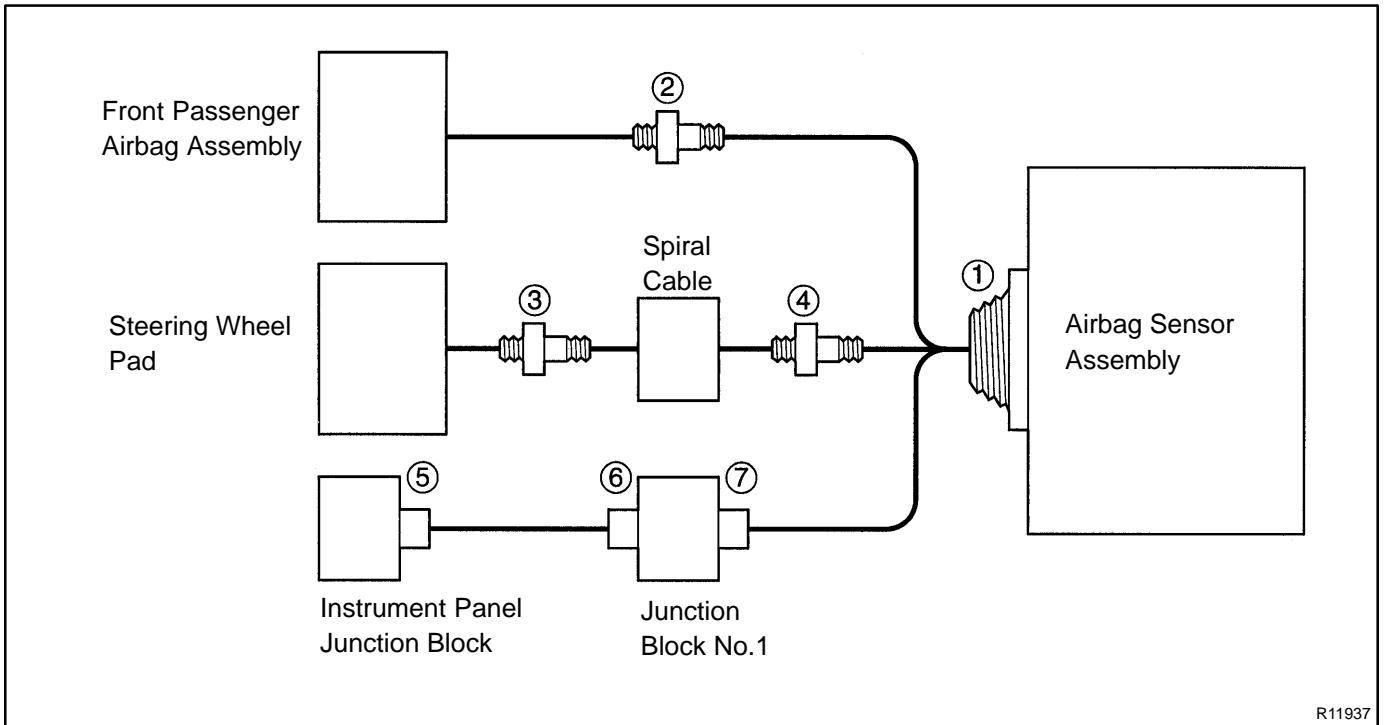

R11937

No.	Item	Application
(1)	Terminal Twin-Lock Mechanism	Connectors 1, 2, 3, 4, 5, 6, 7
(2)	Airbag Activation Prevention Mechanism	Connectors 1, 2, 3, 4
(3)	Electrical Connection Check Mechanism	Connectors 1
(4)	Connector Twin-Lock Mechanism	Connectors 4, 5, 6, 7

- (a) All connectors in the SRS are colored in yellow to distinguish them from other connectors. Connectors having special functions and specifically designed for the SRS are used in the locations shown above to ensure high reliability. These connectors use durable gold-plated terminals.

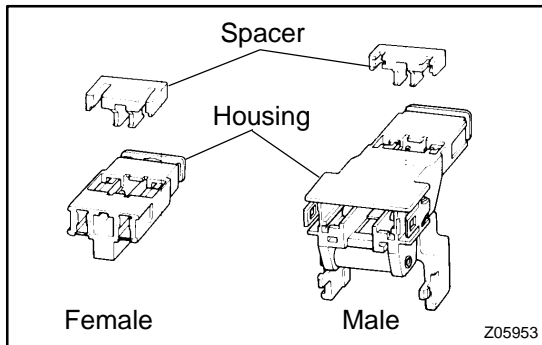

- (1) Terminal Twin-Lock Mechanism
Each connector has a two-piece component consisting of a housing and a spacer. This design enables the terminal to be locked securely by two locking devices (the retainer and the lance) to prevent terminals from coming out.
- (2) Airbag Activation Prevention Mechanism
Each connector contains a short spring plate. When the connector is disconnected, the short spring plate automatically connects the power source and grounding terminals of the squib.

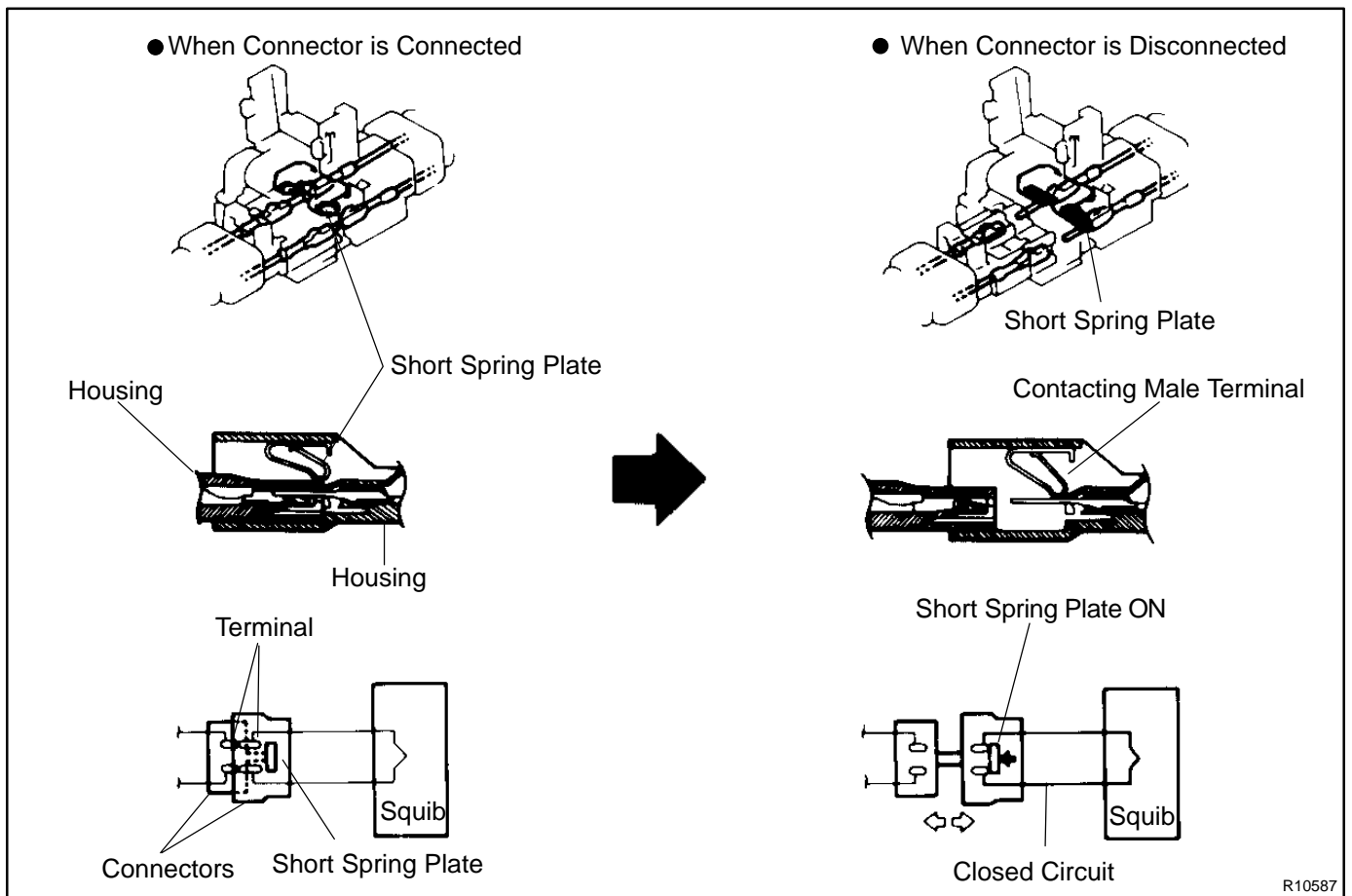

HINT:

The type of connector shown on the previous page is used for connectors "2", "3" and "4" in the diagram on the previous page. Terminal side, but the operating principle is the same.

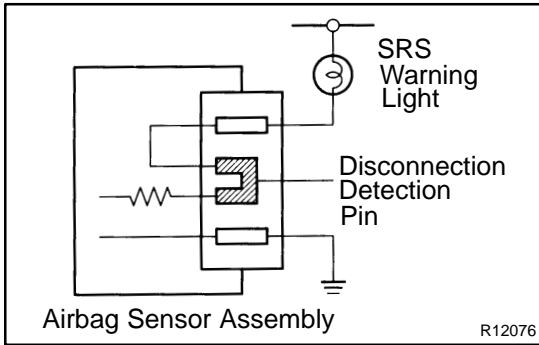

- (3) Electrical Connection Check Mechanism
This mechanism electrically checks that connectors are connected correctly and completely. The electrical connection check mechanism is designed so that the disconnection detection pin connects with the diagnosis terminals when the connector housing lock is locked.

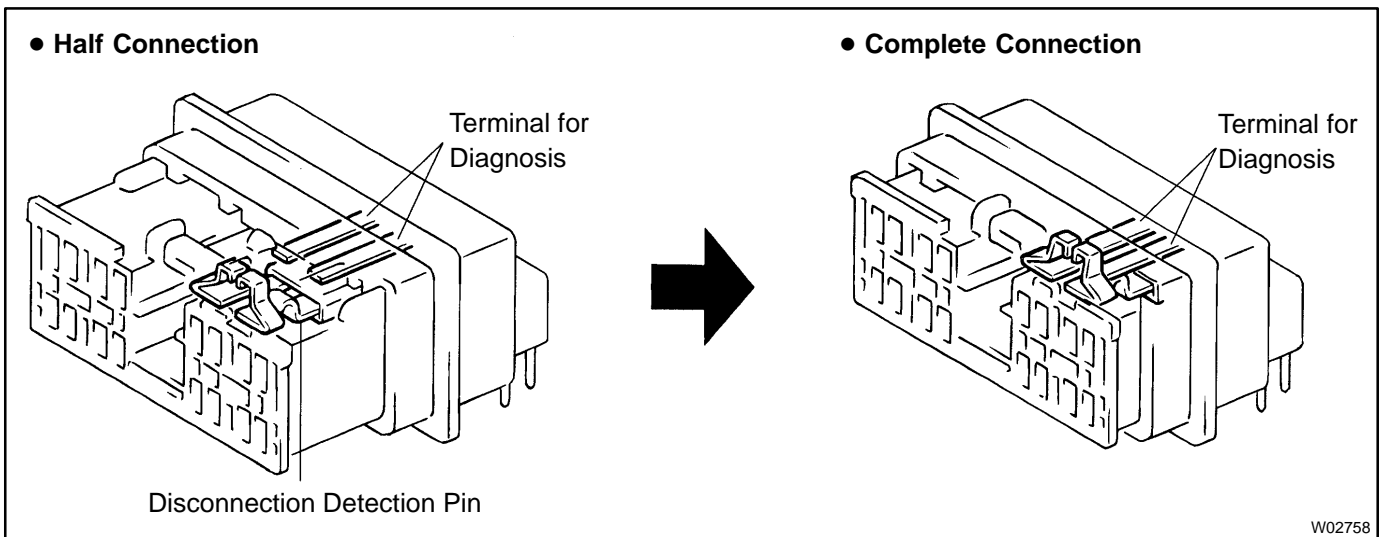

HINT:

The illustration shows connector "1", "2", "3".

- (4) Connector Twin-Lock Mechanism
 With this mechanism connectors (male and female connectors) are locked by 2 locking devices to increase the connection reliability. If the primary lock is incomplete, ribs interfere and prevent the secondary lock.

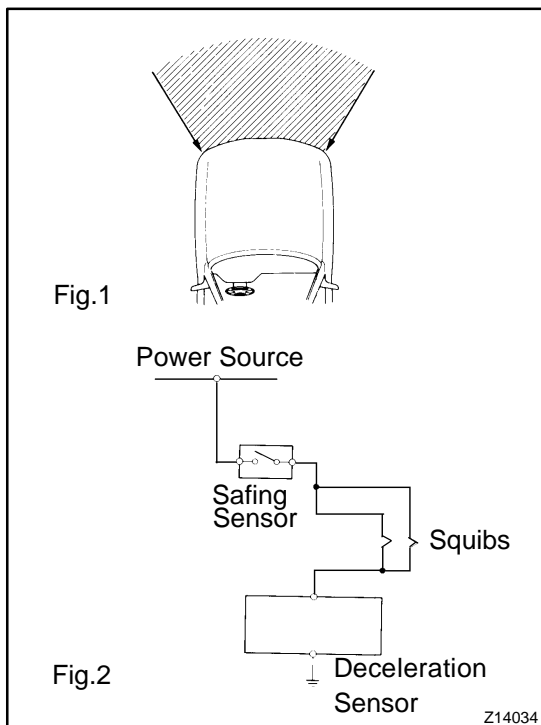
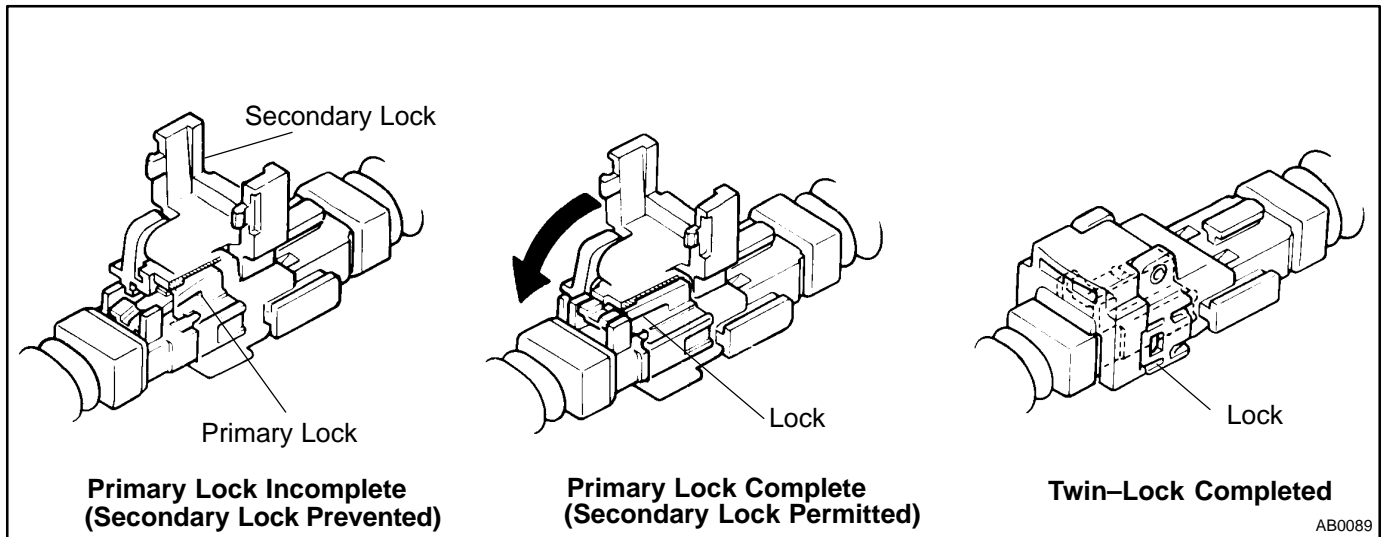

- (b) When the vehicle is involved in a frontal collision in the hatched area (Fig. 1) and the shock is larger than the predetermined level, the SRS is activated automatically. A safing sensor is designed to go on at a smaller deceleration rate than the airbag sensor. As illustrated in Fig. 2, ignition is caused when current flows to the squib, which happens when a safing sensor and the deceleration sensor go on simultaneously. When a deceleration force acts on the sensors, 2 squibs in the driver airbag and front passenger airbag ignite and generate gas. The gas discharging into the driver airbag and front passenger airbag rapidly increases the pressure inside the bags, breaking open the steering wheel pad and instrument panel door. Bag inflation then ends, and the bags deflate as the gas is discharged through discharge holes at the bag's rear or side.

7. DISCONNECTION OF CONNECTORS FOR STEERING WHEEL PAD (with AIRBAG) AND FRONT PASSENGER AIRBAG

- (a) Place a finger on the slider.
- (b) Slide the slider to release lock.
- (c) Disconnect the connector.

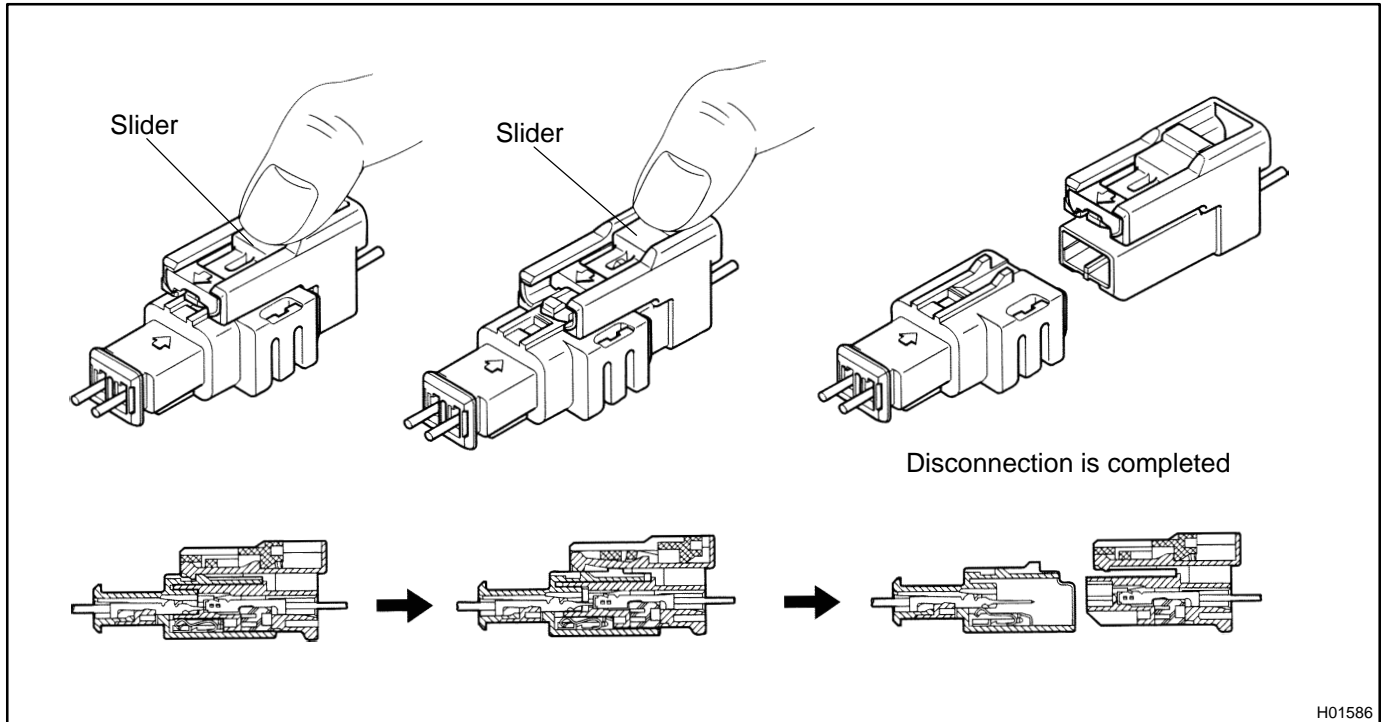

8. CONNECTION OF CONNECTORS FOR STEERING WHEEL PAD (with AIRBAG) AND FRONT PASSENGER AIRBAG

- (a) Align a lock part of male connector and a slider of female connector in the same direction as shown in the illustration, fit in them without rubbing.
- (b) Make sure to insert until they are locked. After fitting in pull them lightly to check that they are locked. (When locked, make sure that the outer returns to its original position and sound at the time of fitting in can be heard.)

HINT:

As the slider slides, do not touch it.

Be careful not to deform the release board. If the release board is deformed, replace it with a new one.

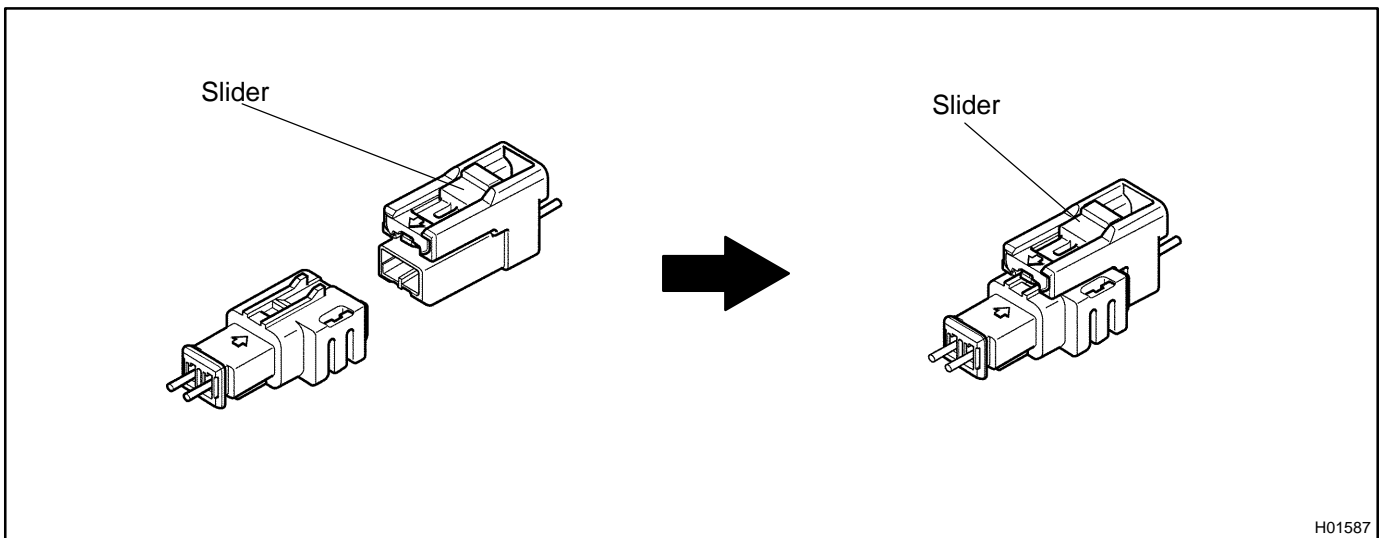

STEERING WHEEL PAD AND SPIRAL CABLE COMPONENTS

RS06N-01

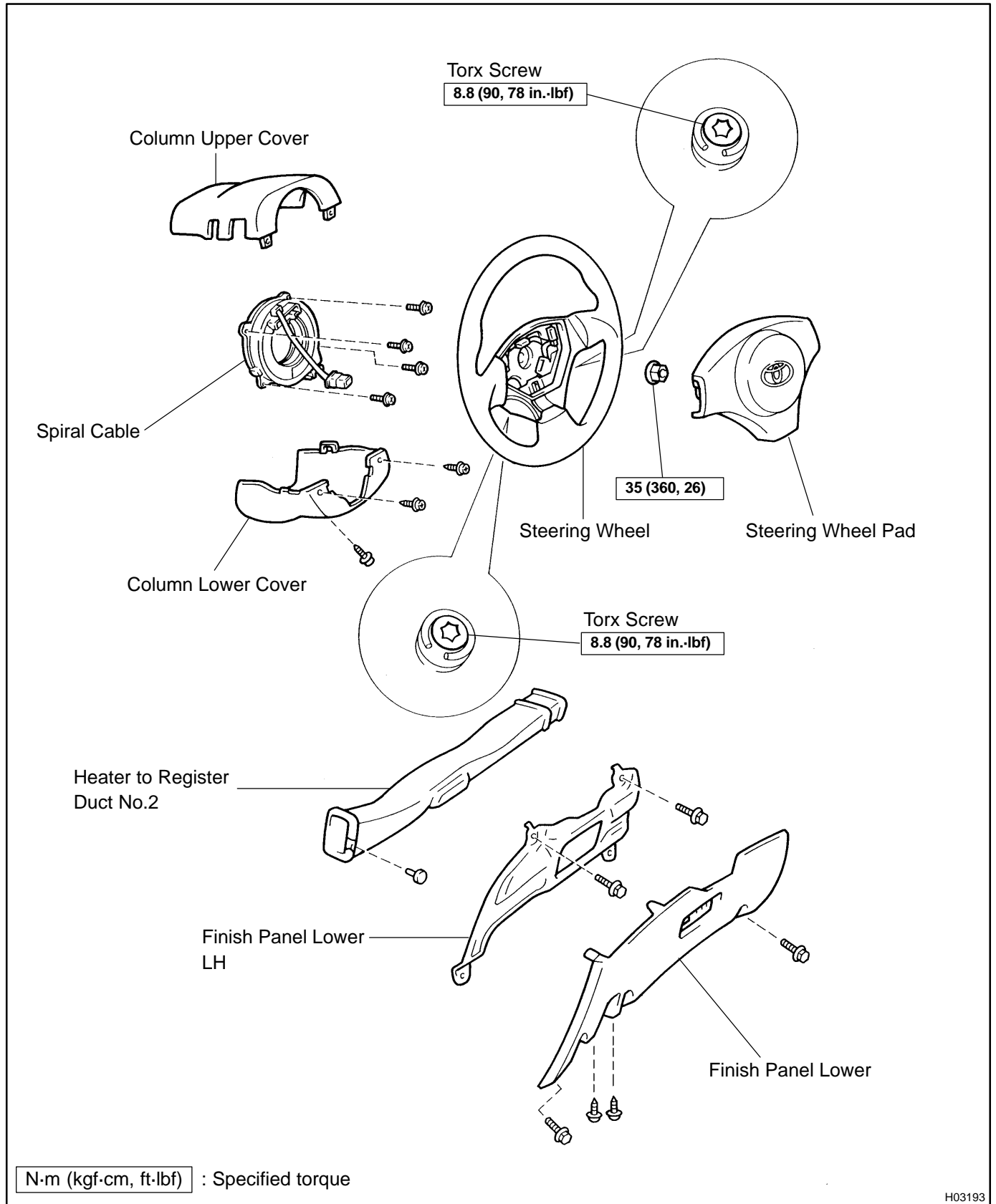

H03193

REMOVAL

(See page [SR-12](#))

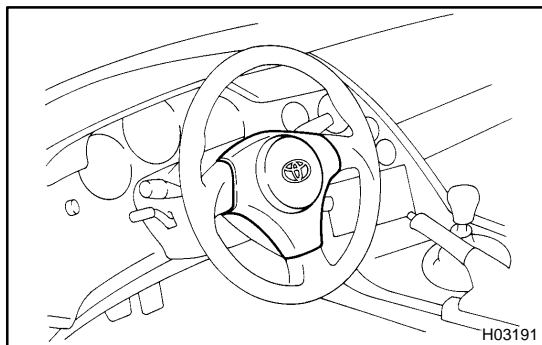

INSPECTION

1. VEHICLES NOT INVOLVED IN A COLLISION

- (a) Do a diagnostic system check.
(See page [DI-589](#))
- (b) Do a visual check which includes the following items with the steering wheel pad (with airbag) installed in the vehicle.
Check cuts, minute cracks or marked discoloration on the steering wheel pad top surface and in the grooved portion.

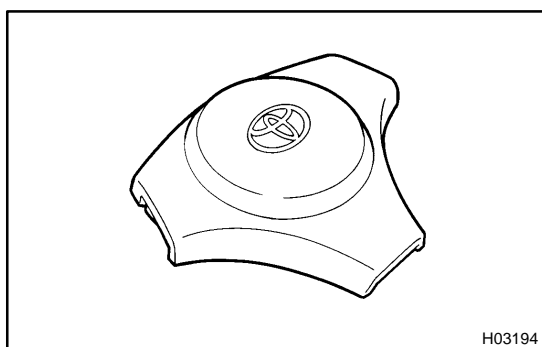

2. VEHICLE INVOLVED IN A COLLISION AND AIRBAG IS NOT DEPLOYED

- (a) Do a diagnostic system check.
(See page [DI-589](#))
- (b) Do a visual check which includes the following items with the steering wheel pad (with airbag) removed from the vehicle.
 - Check cuts minute cracks or marked discoloration on the steering wheel pad top surface and in the grooved portion.
 - Check cuts and cracks in wire harness, and chipping in connectors.
 - Check the deformation of the horn button contact plate of the steering wheel.

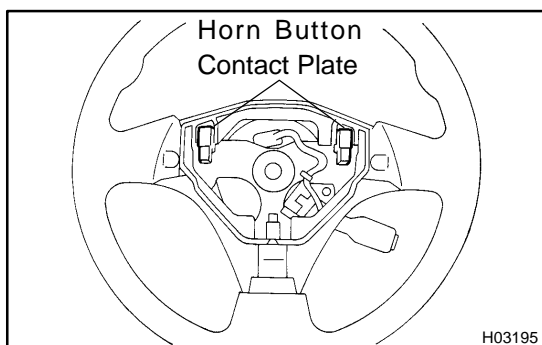

HINT:

- If the horn button contact plate of the steering wheel is deformed, never repair it. Always replace the steering wheel assembly with a new one.

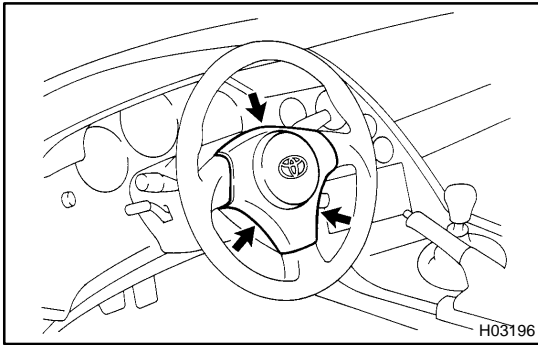

- There should be no interference between the steering wheel pad and steering wheel, and the clearance should be uniform all the way around when the new steering wheel pad is installed on the steering wheel.

CAUTION:

For removal and installation of the steering wheel pad, see page [SR-12](#), [SR-22](#) and be sure to follow the correct procedure.

3. VEHICLE INVOLVED IN A COLLISION AND AIRBAG IS DEPLOYED

- (a) Do a diagnostic system check.
(See page [DI-589](#))
- (b) Do a visual check which includes the following items with the steering wheel pad (with airbag) removed from the vehicle.
 - Check the deformation on the horn button contact plate of the steering wheel.
 - Check the damage on the spiral cable connector and wire harness.

HINT:

- If the horn button contact plate of the steering wheel is deformed, never repair it. Always replace the steering wheel assembly with a new one.
- There should be no interference between the steering wheel pad and steering wheel, and the clearance should be uniform all the way around when the new steering wheel pad is installed on the steering wheel.

DISPOSAL

HINT:

When a scrapping vehicle equipped with an SRS or disposing of a steering wheel pad (with airbag), always first deploy the airbag in accordance with the procedure described below. If any abnormality occurs with the airbag deployment, contact the SERVICE DEPT. of TOYOTA MOTOR SALES, U.S.A., INC. When disposing of a steering wheel pad with an airbag deployed in a collision, follow the same procedure given in step 1-(g) in "DISPOSAL".

CAUTION:

- Never dispose of a steering wheel pad which has an undeployed airbag.
- The airbag produces a sizeable exploding sound when it deploys, so perform the operation out-of-doors and where it will not create a nuisance to nearby residents.

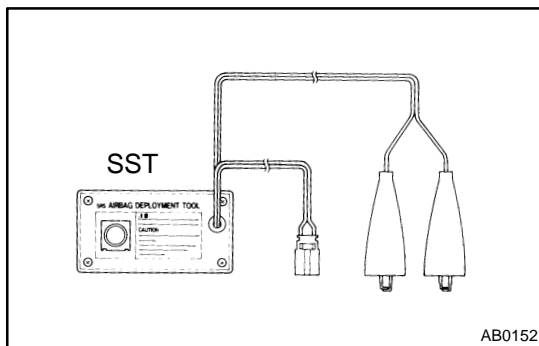

- When deploying the airbag, always use the specified SST (SRS Airbag Deployment Tool). Perform the operation in a place away from electrical noise.
SST 09082-00700, 09082-00760
- When deploying an airbag, perform the operation at least 10 m (33 ft) away from the steering wheel pad.
- The steering wheel pad is very hot when the airbag is deployed, so leave it alone for at least 30 minutes after deployment.
- Use gloves and safety glasses when handling a steering wheel pad with the deployed airbag.
- Always wash your hands with water after completing the operation.
- Do not apply water, etc. to a steering wheel pad with the deployed airbag.

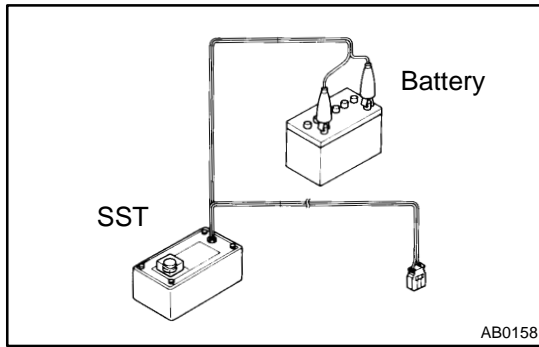

1. AIRBAG DEPLOYMENT WHEN SCRAPPING VEHICLE

HINT:

Have a battery ready as the power source to deploy the airbag.

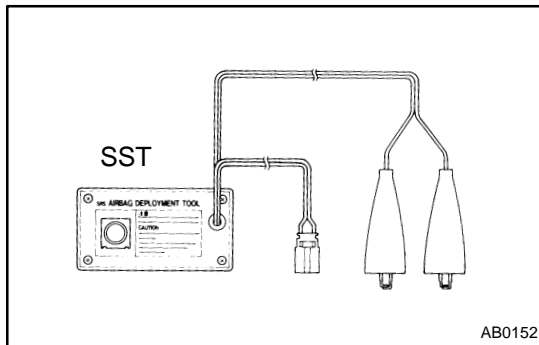

(a) Confirm functioning of the SST.

CAUTION:

When deploying the airbag, always use the specified SST: SRS Airbag Deployment Tool.

SST 09082-00700

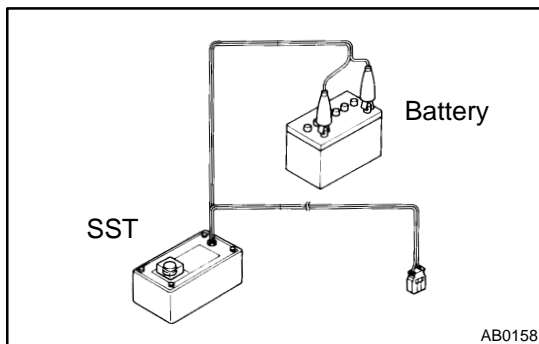

(1) Connect the SST to the battery.

Connect the red clip of the SST to the battery positive (+) terminal and the black clip to the battery negative (-) terminal.

HINT:

Do not connect the yellow connector which will be connected with the supplemental restraint system.

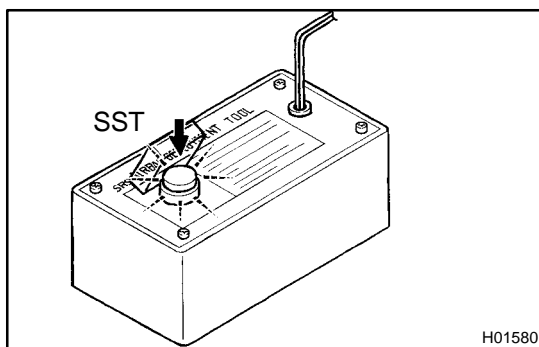

(2) Confirm functioning of the SST.

Press the SST activation switch, and check that the LED of the SST activation switch lights up.

CAUTION:

If the LED lights up when the activation switch is not being pressed, SST malfunction is probable, so definitely do not use the SST.

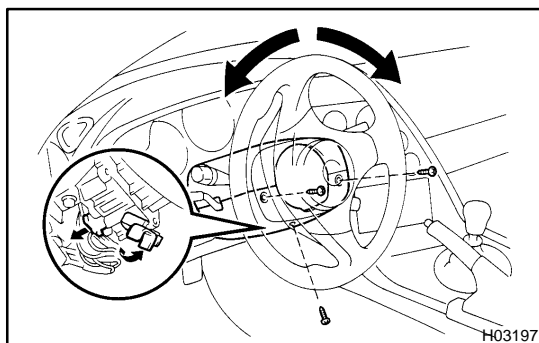

(b) Install the SST.

CAUTION:

Check that there is no looseness in the steering wheel and steering wheel pad.

(1) Remove the finish panel lower and finish panel lower LH.

Remove the 3 screws and steering column lower cover as shown in the illustration.

(2) Disconnect the airbag connector of the spiral cable.

SUPPLEMENTAL RESTRAINT SYSTEM – STEERING WHEEL PAD AND SPIRAL CABLE

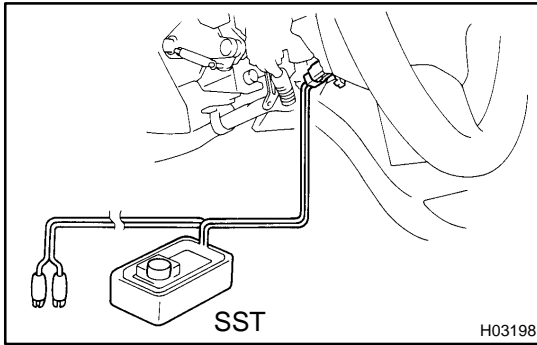

- (3) Connect the SST connector to the airbag connector of the spiral cable.

SST 09082-00700

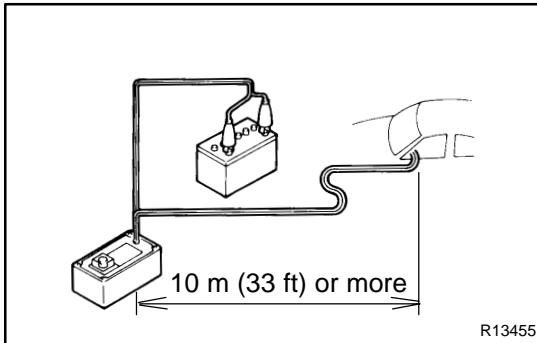

- (4) Move the SST at least 10 m (33 ft) away from the front of the vehicle.

- (5) Close all the doors and window of the vehicle.

NOTICE:

Take care not to damage the SST wire harness.

- (6) Connect the SST red clip to the battery positive (+) terminal and the black clip to the negative (-) terminal.

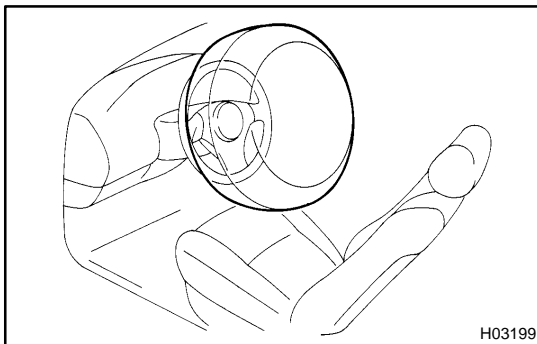

- (c) Deploy the airbag.

- (1) Confirm that no one is inside the vehicle or within 10 m (33 ft) area around the vehicle.

- (2) Press the SST activation switch and deploy the airbag.

HINT:

The airbag deploys simultaneously as the LED of the SST activation switch lights up.

- (d) Dispose of steering wheel pad (with airbag).

CAUTION:

- **The steering wheel pad is very hot when the airbag is deployed, so leave it alone for at least 30 minutes after deployment.**
- **Use gloves and safety glasses when handling a steering wheel pad with the deployed airbag.**
- **Always wash your hands with water after completing the operation.**
- **Do not apply water, etc. to a steering wheel pad with the deployed airbag.**
 - (1) When scrapping a vehicle, deploy the airbag and scrap the vehicle with the steering wheel pad still installed.
 - (2) When moving a vehicle for scrapping which has a steering wheel pad with deployed airbag, use gloves and safety glasses.

2. DEPLOYMENT WHEN DISPOSING OF STEERING WHEEL PAD ONLY

NOTICE:

- When disposing of the steering wheel pad (with airbag) only, never use the customer's vehicle to deploy the airbag.
- Be sure to follow the procedure given below when deploying the airbag.

HINT:

Have a battery ready as the power source to deploy the airbag.

(a) Remove the steering wheel pad.

(See page [SR-12](#))

CAUTION:

When storing the steering wheel pad, keep the upper surface of the pad facing upward.

(b) Remove the steering wheel pad connector.

Remove the connector on the rear surface of the steering wheel pad from the bracket.

(c) Remove the steering wheel pad cover.

(d) Fix the steering wheel pad to the disc wheel with tire.

(1) Install the 2 bolts with washers in the 2 bolt holes on the steering wheel pad.

Bolt:

L: 35. mm (1.387 in.)

M: 6.0 mm (0.236 in.)

Pitch: 1.0 mm (0.039 in.)

NOTICE:

- Tighten the bolts by hand until the bolts become difficult to turn.
- Do not tighten the bolts too much.

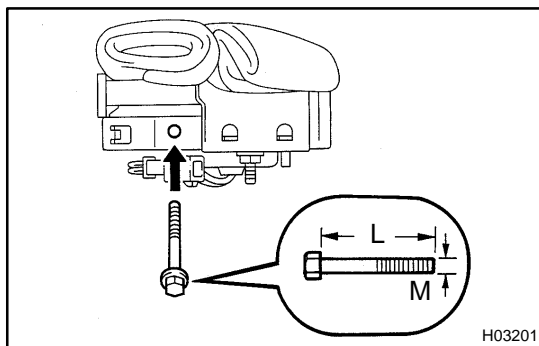
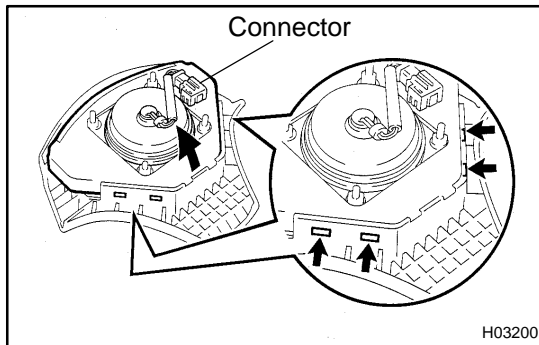

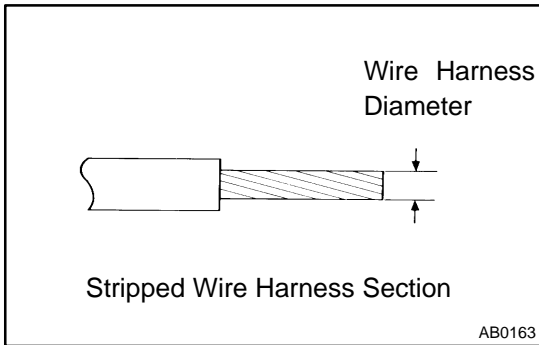

- (2) Using a service-purpose wire harness tie down the steering wheel pad to the disc wheel.

Wire harness: Stripped wire harness section 1.25 mm² or more (0.0019 in². or more).

HINT:

To calculate the square of the stripped wire harness section:
 Square – 3.14 x (Diameter)² divided by 4

CAUTION:

If a wire harness which is too thin or some other thing is used to tie down the steering wheel pad, it may be snapped by the shock when the airbag is deployed. This is highly dangerous. Always use a wire harness for vehicle use which is at least 1.25 mm² (0.0019 in²).

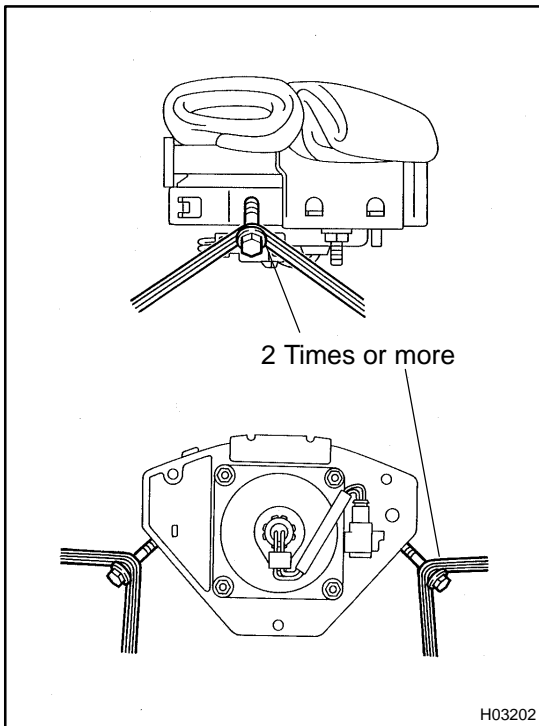

- (3) Using 3 wire harness, wrap the wire harness at least 2 times each around the bolts installed on the left and right sides of the steering wheel pad.

CAUTION:

- **Tightly wind the wire harness around the bolts so that there is no slack.**
- **If there is slackness in the wire harness, the steering wheel pad may come loose due to the shock when the airbag is deployed. This is highly dangerous.**

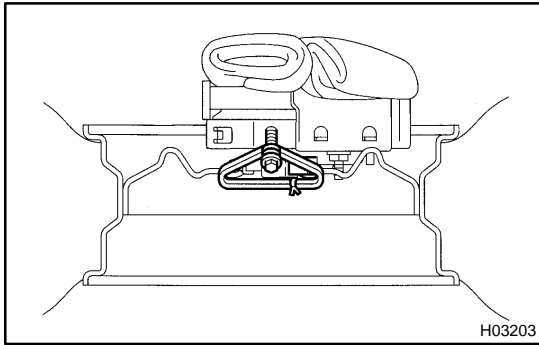

- (4) Face the upper surface of the steering wheel pad upward. Separately tie the left and right sides of the steering wheel pad to the disc wheel through the hub nut holes. Position the steering wheel pad connector so that it hangs downward through a hub hole in the disc wheel.

CAUTION:

- Make sure that the wire harness is tight. It is very dangerous when looseness in the wire harness results in the steering wheel pad coming free through the shock from the airbag deploying.
- Always tie down the steering wheel pad with the pad side facing upward. It is very dangerous if the steering wheel pad is tied down with the metal surface facing upward as the wire harness will be cut by the shock of the airbag deploying and the steering wheel pad will be thrown into the air.

NOTICE:

The disc wheel will be marked by airbag deployment, so use the spare disc wheel.

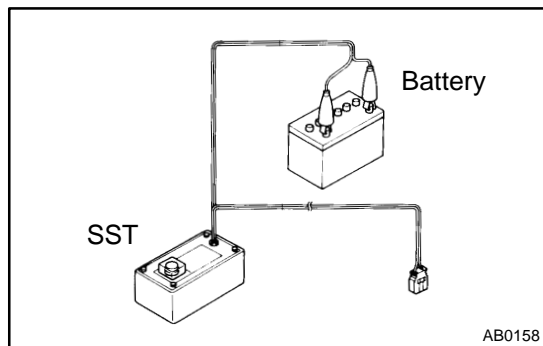

- (e) Confirm functioning of the SST.
SST 09082-00700, 09082-00760

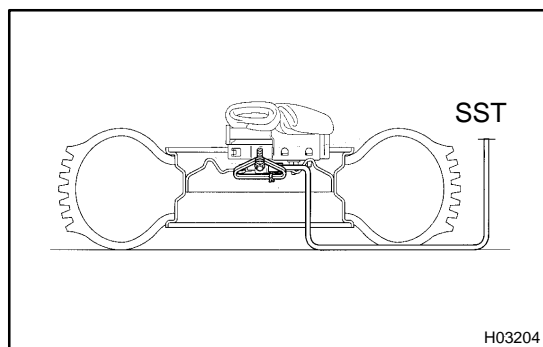

- (f) Install the SST.

CAUTION:

Place the disc wheel on the level ground.

- (1) Connect the 2 SST connector to the steering wheel pad connector.
SST 09082-00700, 09082-00760

NOTICE:

To avoid damaging the SST connector and wire harness, do not lock the secondary lock of the twin lock. Also, secure some slack for the SST wire harness inside the disc wheel.

- (2) Move the SST to at least 10 m (33 ft) away from the steering wheel pad tied down on the disc wheel.

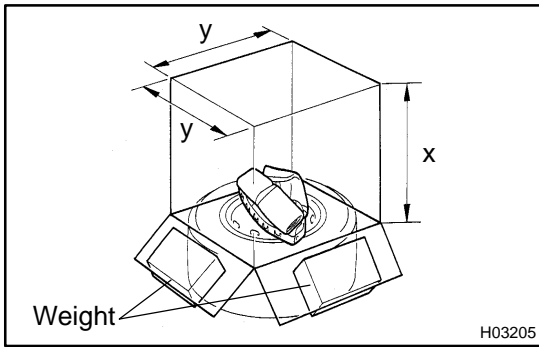

- (g) Cover the steering wheel pad with cardboard box or tires.
- Covering method using cardboard box:
Cover the steering wheel pad with the cardboard box and weight the cardboard box down in 4 places with at least 196 N (20 kg, 44 lb).

Size of cardboard box:

Must exceed the following dimensions:

x=460 mm (18.11 in.)

When dimension of the cardboard box exceeds the diameter of the disc wheel with tire to which the steering wheel pad is tied –

x=460 mm (18.11 in.) + width of tire

y= 650 mm (25.59 in.)

NOTICE:

If a cardboard box smaller than the specified size is used, the cardboard box will be broken by the shock from the airbag deployment.

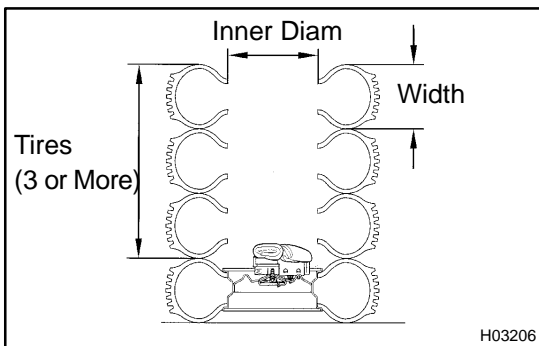

- Covering method using tires:
Place at least 3 tires without disc wheel on top of the disc wheel with tire to which the steering wheel pad is tied.

Tire size: Must exceed the following dimensions–

Width: 185 mm (7.28 in.)

Inner diameter: 360 mm (14.17 in.)

CAUTION:

Do not use tires with disc wheels.

NOTICE:

The tires may be marked by the airbag deployment, so use the spare tires.

- (h) Deploy the airbag.
- (1) Connect the SST red clip to the battery positive (+) terminal and the black clip to the battery negative (–) terminal.
 - (2) Check that no one is within 10 m (33 ft) area around the disc wheel which the steering wheel pad is tied to.

- (3) Press the SST activation switch and deploy the airbag.

HINT:

The airbag deploys simultaneously as the LED of the SST activation switch lights up.

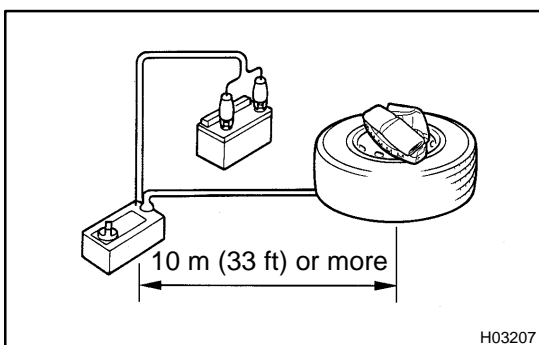

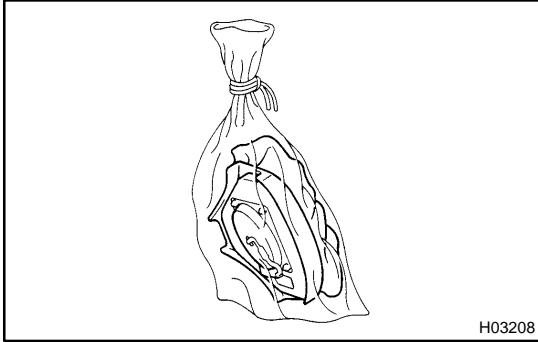

(i) Dispose of the steering wheel pad (with airbag).

CAUTION:

- **The steering wheel pad is very hot when the airbag is deployed, so leave it alone for at least 30 minutes after deployment.**
- **Use gloves and safety glasses when handling a steering wheel pad with deployed airbag.**
- **Always wash your hands with water after completing the operation.**
- **Do not apply water, etc. to a steering wheel pad with deployed airbag.**
 - (1) Remove the steering wheel pad from the disc wheel.
 - (2) Place the steering wheel pad in a vinyl bag, tie the end tightly and dispose of it in the same way as other general parts disposal.

REPLACEMENT

REPLACEMENT REQUIREMENTS

In the following cases, replace the steering wheel pad, steering wheel or spiral cable.

- If the airbag has been deployed.
- If the steering wheel pad or spiral cable has been found to be faulty in troubleshooting.
- If the steering wheel pad, steering or spiral cable has been found to be faulty during the check in items. (See page [RS-11](#))
- If the steering wheel pad has been dropped.

CAUTION:

For removal and installation of the steering wheel pad, see page [SR-12](#) and [SR-22](#). Be sure to follow the correct procedure.

INSTALLATION

(See page [SR-22](#))

FRONT PASSENGER AIRBAG ASSEMBLY COMPONENTS

RS08T-01

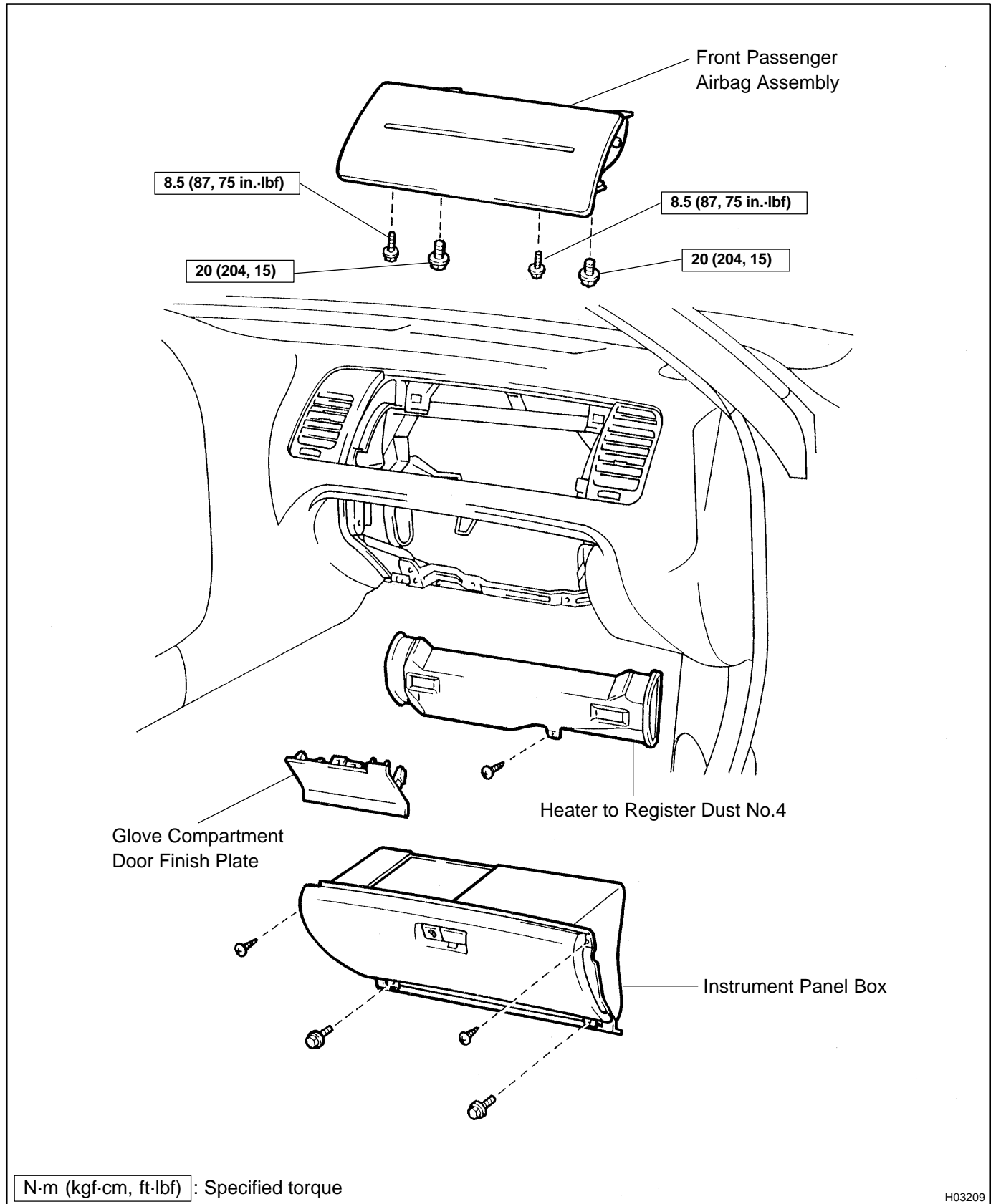

REMOVAL

NOTICE:

- If the wiring connector of the SRS is disconnected and the ignition switch is at ON or ACC position, DTCs will be recorded.
- Never use the airbag parts from another vehicle. When replacing parts, replace with new parts.

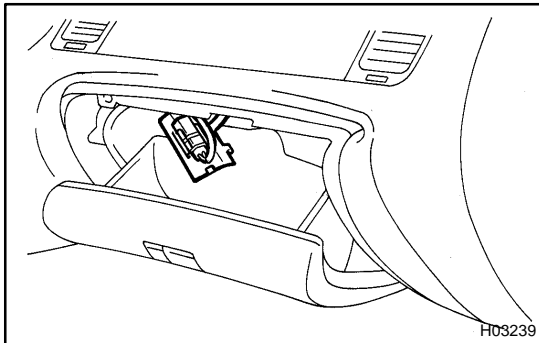

1. DISCONNECT AIRBAG CONNECTOR

- Remove the glove compartment door finish plate inside the instrument panel box.

NOTICE:

When handling the airbag connector, take care not to damage the airbag wire harness.

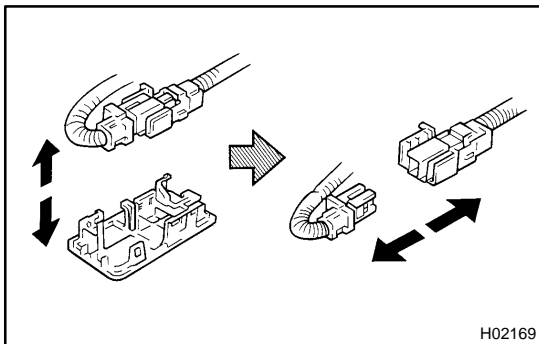

- Pull up the connector.
- Disconnect the front passenger airbag connector.

2. REMOVE THESE PARTS: (See page [BO-50](#))

- Instrument panel box
- Heater to register duct No.4

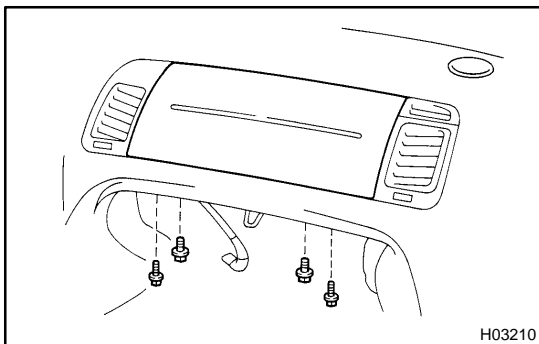

3. REMOVE FRONT PASSENGER AIRBAG ASSEMBLY

- Remove the 4 bolts.
- Pull the front passenger airbag assembly to remove it.

CAUTION:

- Do not store the front passenger airbag assembly with the airbag deployment direction facing downward.
- Never disassemble the front passenger airbag assembly.

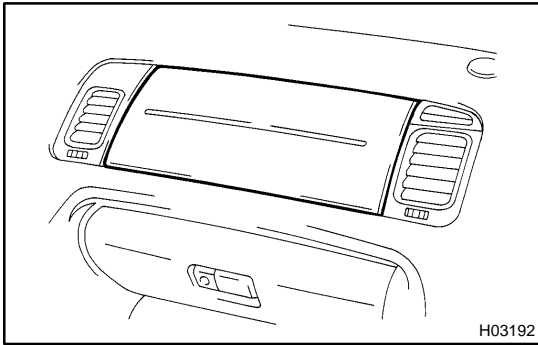

H03192

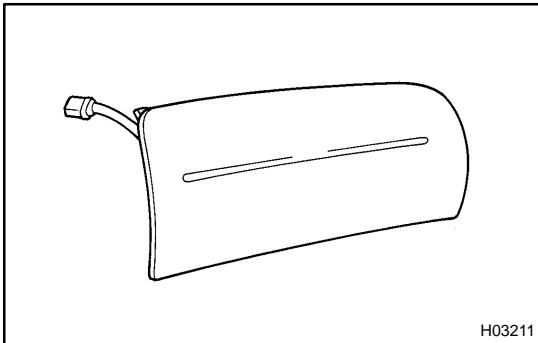

H03211

INSPECTION

1. VEHICLES NOT INVOLVED IN A COLLISION

- (a) Do a diagnostic system check.
(See page [DI-589](#))
- (b) Do a visual check which includes the following items with the front passenger airbag assembly installed in the vehicle.
Check cuts, minute cracks or marked discoloration on the front passenger airbag assembly and instrument panel.

2. VEHICLE INVOLVED IN A COLLISION AND AIRBAG IS NOT DEPLOYED

- (a) Do a diagnostic system check.
(See page [DI-589](#))
- (b) Do a visual check which includes the following items with the front passenger airbag assembly removed from the vehicle.
 - Check cuts minute cracks or marked discoloration on the front passenger airbag assembly.
 - Check cuts and cracks in wire harness, and for chipping in connectors.
 - Check the deformation or cracks on the instrument panel and instrument panel reinforcement.

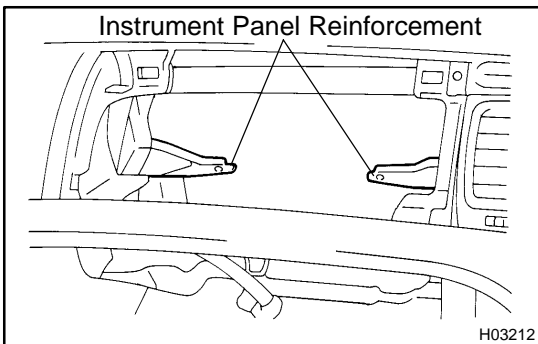

H03212

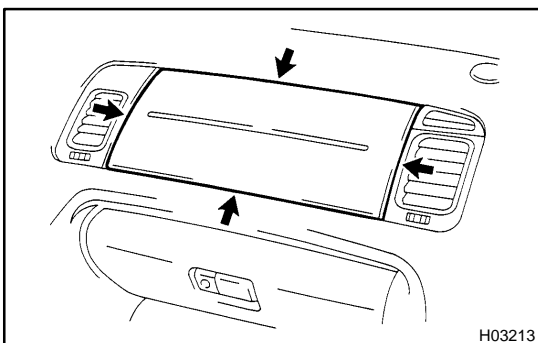

H03213

HINT:

- If the instrument panel or instrument panel reinforcement is deformed or cracked, never repair it. Always replace it with a new one.

- There should be no interference between the instrument panel and the front passenger airbag assembly.

CAUTION:

For removal and installation of the front passenger airbag assembly, see page [RS-24](#), [RS-35](#) and be sure to follow the correct procedure.

3. VEHICLE INVOLVED IN A COLLISION AND AIRBAG IS DEPLOYED

- (a) Do a diagnostic system check.
(See page [DI-589](#))
- (b) Do a visual check which includes the following items with the front passenger airbag assembly removed from the vehicle.
 - Check the deformation or cracks on the instrument panel and instrument panel reinforcement.
 - Check the damage on the connector and wire harness.

HINT:

If the instrument panel or instrument panel reinforcement is deformed or cracked, never repair it. Always replace it with a new one.

DISPOSAL

HINT:

When a scrapping vehicle equipped with an SRS or disposing of a front passenger airbag assembly, always first deploy the airbag in accordance with the procedure described below. If any abnormality occurs with the airbag deployment, contact the SERVICE DEPT. of TOYOTA MOTOR SALES, U.S.A., INC. When disposing of a front passenger airbag assembly with an airbag deployed in a collision, follow the same procedure given in step 1–(e) in "DISPOSAL".

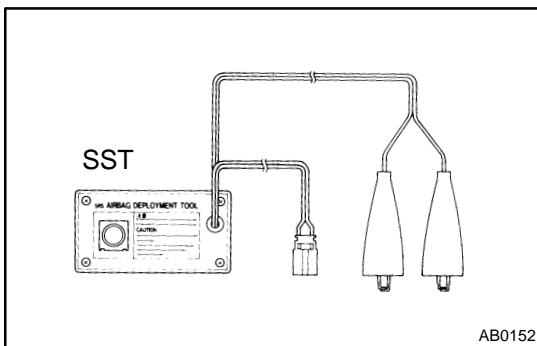

CAUTION:

- Never dispose of a front passenger airbag assembly which has an undeployed airbag.
- The airbag produces a sizeable exploding sound when it deploys, so perform the operation out-of-doors and where it will not create a nuisance to nearby residents.
- When deploying the airbag, always use the specified SST (SRS Airbag Deployment Tool). Perform the operation in a place away from electrical noise.
SST 09082-00700
- When deploying an airbag, perform the operation from at least 10 m (33 ft) away from the front passenger airbag assembly.
- The front passenger airbag assembly is very hot when the airbag is deployed, so leave it alone for at least 30 minutes after deployment.
- Use gloves and safety glasses when handling a front passenger airbag assembly with deployed airbag.
- Always wash your hands with water after completing the operation.
- Do not apply water, etc. to a front passenger airbag assembly with deployed airbag.

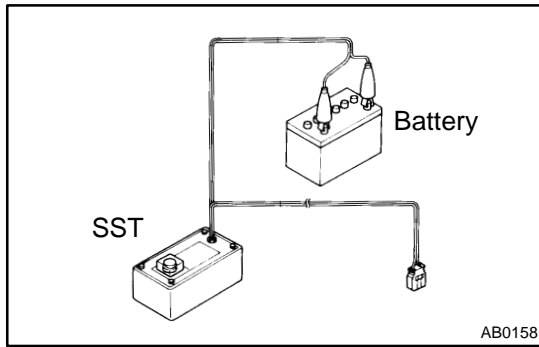

1. AIRBAG DEPLOYMENT WHEN SCRAPPING VEHICLE

HINT:

Have a battery ready as the power source to deploy the airbag.

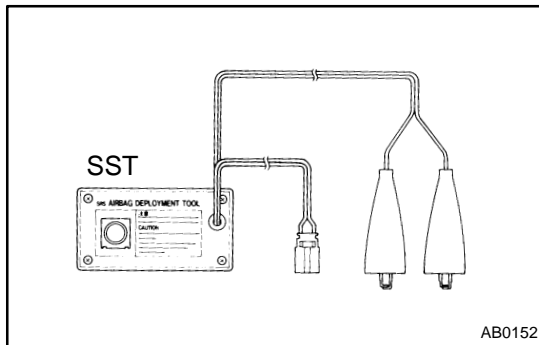

(a) Confirm functioning of the SST.

CAUTION:

When deploying the airbag, always use the specified SST:
SRS Airbag Deployment Tool.

SST 09082-00700

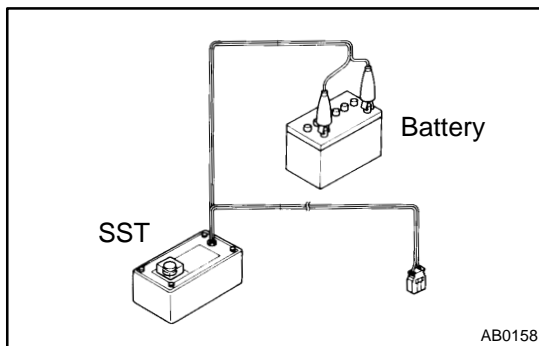

(1) Connect the SST to battery.

Connect the red clip of the SST to the battery positive (+) terminal and the black clip to the battery negative (-) terminal.

HINT:

Do not connect the yellow connector which will be connected with the supplemental restraint system.

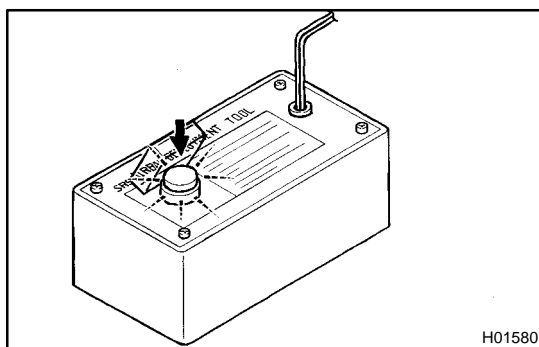

(2) Confirm functioning of the SST.

Press the SST activation switch, and confirm the LED of the SST activation switch lights up.

CAUTION:

If the LED lights up when the activation switch is not being pressed, SST malfunction is probable, so definitely do not use the SST.

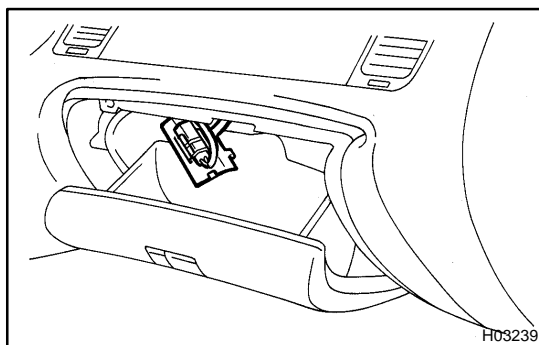

(b) Disconnect the airbag connector.

(1) Remove the glove compartment finish plate inside the instrument panel box.

NOTICE:

When handling the airbag connector, take care not to damage the airbag wire harness.

SUPPLEMENTAL RESTRAINT SYSTEM – FRONT PASSENGER AIRBAG ASSEMBLY

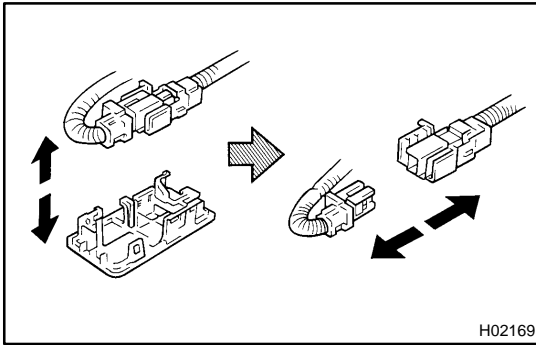

- (2) Pull up the connector.
- (3) Disconnect the airbag connector.

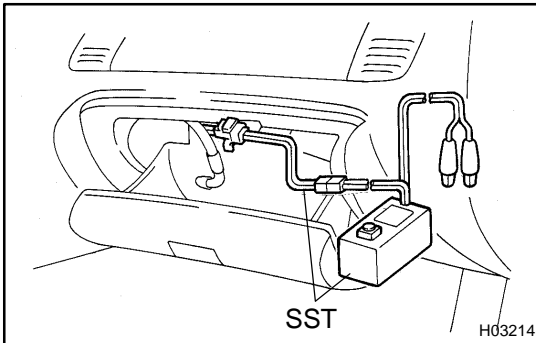

- (c) Install the SST.
 - (1) Connect the connector of 2 SST to the front passenger airbag assembly connector.
- SST 09082-00700, 09082-00760

NOTICE:

To avoid damaging the SST connector and wire harness, do not lock the secondary lock of the twin lock.

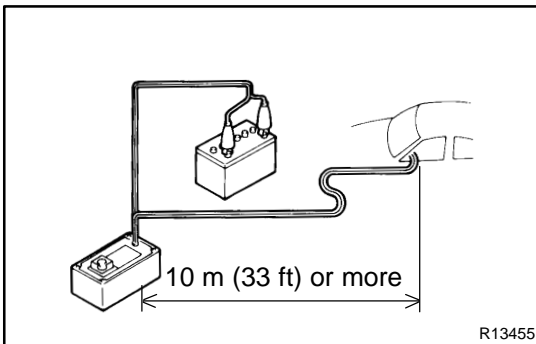

- (2) Move the SST to at least 10 m (33 ft) from the front of the vehicle.
- (3) Close all the doors and windows of the vehicle.

NOTICE:

Take care not to damage the SST wire harness.

- (4) Connect the SST red clip to the battery positive (+) terminal and the black clip to the negative (-) terminal.

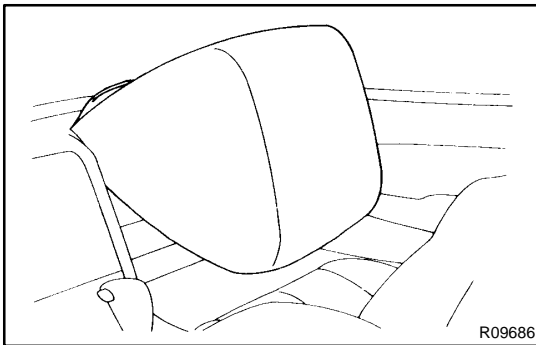

- (d) Deploy the airbag.
 - (1) Confirm that no-one is inside the vehicle or within 10 m (33 ft) area around the vehicle.
 - (2) Press the SST activation switch and deploy the airbag.

HINT:

The airbag deploys simultaneously as the LED of the SST activation switch lights up.

- (e) Dispose of the front passenger airbag assembly.

CAUTION:

- The front passenger airbag assembly is very hot when the airbag is deployed, so leave it alone for at least 30 minutes after deployment.
- Use gloves and safety glasses when handling a front passenger airbag assembly with deployed airbag.
- Always wash your hands with water after completing the operation.
- Do not apply water, etc. to a front passenger airbag assembly with deployed airbag.

(1) When scrapping a vehicle, deploy the airbag and scrap the vehicle with the front passenger airbag assembly still installed.

(2) When moving a vehicle for scrapping which has a front passenger airbag assembly with deployed airbag, use gloves and safety glasses.

2. DEPLOYMENT WHEN DISPOSING OF FRONT PASSENGER AIRBAG ASSEMBLY ONLY**NOTICE:**

- When disposing of the front passenger airbag assembly only, never use the customer's vehicle to deploy the airbag.
- Be sure to follow the procedure given below when deploying the airbag.

HINT:

Have a battery ready as the power source to deploy the airbag.

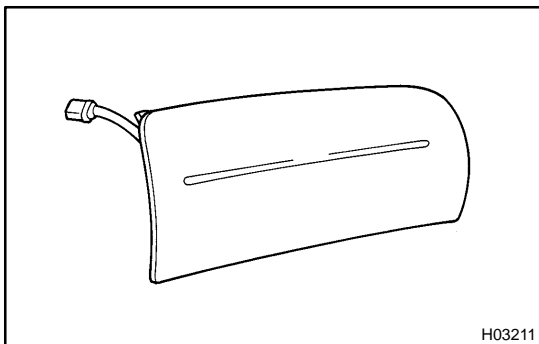

- (a) Remove the front passenger airbag assembly.
(See page [RS-24](#))

CAUTION:

- When removing the front passenger airbag assembly, work must be started after 90 seconds from the time the ignition switch is turned to the "LOCK" position and the negative (-) terminal cable is disconnected from the battery.
- Store the front passenger airbag assembly with the airbag deployment direction facing upward.

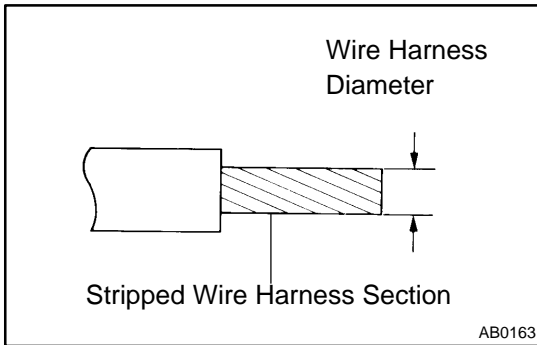

- (b) Fix the front passenger airbag assembly to tire.
- (1) Using a service-purpose wire harness for the vehicle, tie down the front passenger airbag assembly to the tire.

**Wire harness: Stripped wire harness section
1.25 mm² or more (0.0019 in.² or more)**

HINT:

To calculate the square of the stripped wire harness section:

$$\text{Square} = 3.14 \times (\text{Diameter})^2 \text{ divided by } 4$$

CAUTION:

If a wire harness which is too thin or some other thing is used to tie down the front passenger airbag assembly it may be snapped by the shock when the airbag is deployed. This is highly dangerous. Always use a wire harness for vehicle use which is at least 1.25 mm² (0.0019 in²).

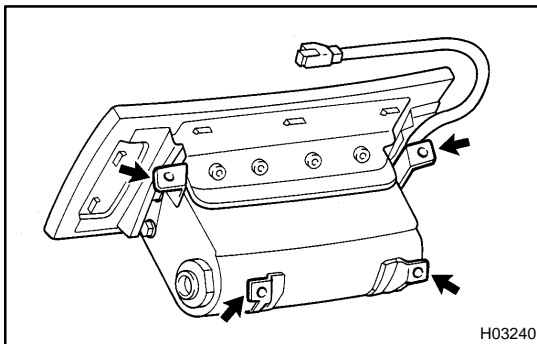

- (2) Wrap the wire harness around the tire, passing the wire harness through the installation holes indicated by arrows in the installation.

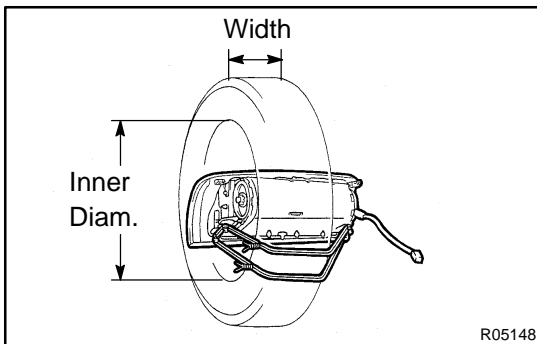

- (3) Position the front passenger airbag assembly inside the tire with the airbag deployment direction facing inside.

Tire size: Must exceed the following dimensions–

Width: 185 mm (7.28 in.)

Inner diameter: 360 mm (14.17 in.)

CAUTION:

- Make sure that the wire harness is tight. It is very dangerous if looseness in the wire harness results in the front passenger airbag assembly coming free due to the shock of the airbag deploying.
- Always tie down the front passenger airbag assembly with the airbag door facing inside.

NOTICE:

The tire will be marked by the airbag deployment, so use a redundant tire.

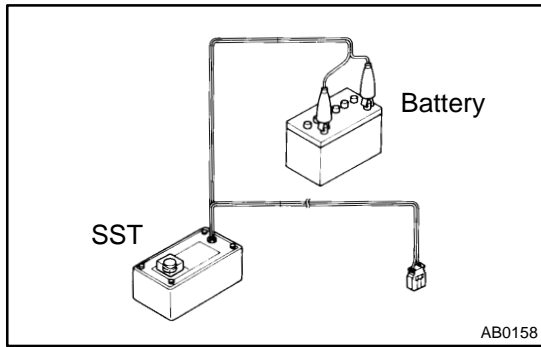

- (c) Confirm functioning of the SST.
SST 09082-00700

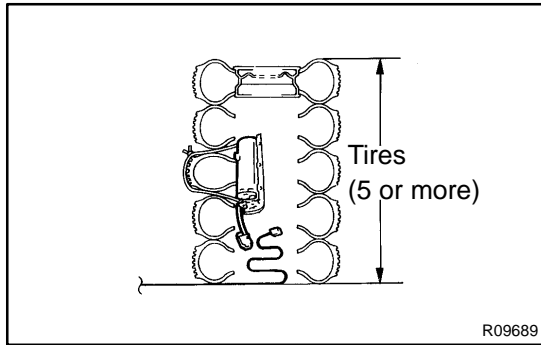

- (d) Place tires.
 - (1) Place at least 2 tires under the tire to which the front passenger airbag assembly is tied.
 - (2) Place at least 2 tires over the tire to which the front passenger airbag assembly is tied. The top tire should have the wheel installed.
 - (3) Tie the tires together with 2 wire harnesses.

CAUTION:

Make sure that the wire harnesses are tight. It is very dangerous if loose wire harnesses result in the tires coming free due to the shock of the airbag deploying.

HINT:

Place the SST connector and wire harness inside tires. Provide at least 1 m (3 ft) of slack for the wire harness.

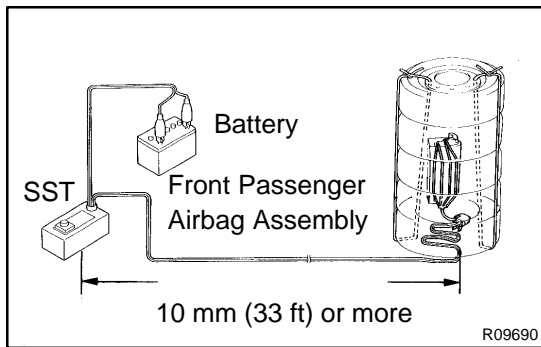
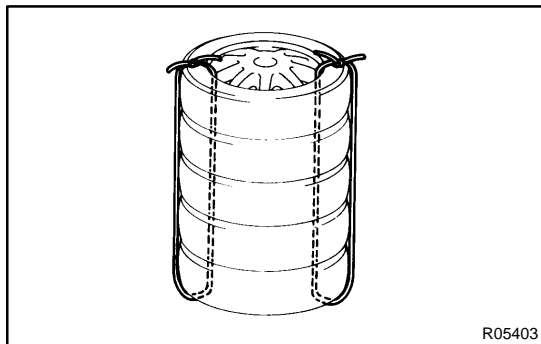

- (e) Install the SST.
Connect the connector of 2 SST to the front passenger airbag assembly connector.
SST 09082-00700, 09082-00760

NOTICE:

To avoid damaging the SST connector and wire harness, do not lock the secondary lock of the twin lock.

- (f) Deploy the airbag.
 - (1) Connect the SST red clip to the battery positive (+) terminal and the black clip to the battery negative (-) terminal.
 - (2) Confirm that no-one is within 10 m (33 ft) area around the tire which the front passenger airbag assembly is tied to.
 - (3) Press the SST activation switch and deploy the airbag.

HINT:

The airbag deploys simultaneously as the LED of the SST activation switch lights up.

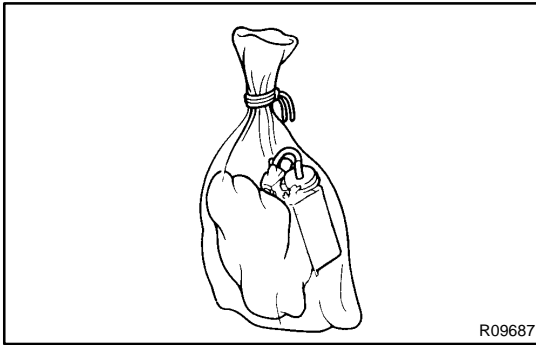

(g) Dispose of the front passenger airbag assembly.

CAUTION:

- **The front passenger airbag assembly is very hot when the airbag is deployed, so leave it alone for at least 30 minutes after deployment.**
- **Use gloves and safety glasses when handling a front passenger airbag assembly with deployed airbag.**
- **Always wash your hands with water after completing the operation.**
- **Do not apply water, etc. to a front passenger airbag assembly with deployed airbag.**
 - (1) Remove the front passenger airbag assembly from the tire.
 - (2) Place the front passenger airbag assembly in a vinyl bag, tie the end tightly and dispose of it in the same way as other general parts.

REPLACEMENT

REPLACEMENT REQUIREMENTS

In the following cases, replace the front passenger airbag assembly, instrument panel or instrument panel reinforcement.

- If the airbag has been deployed.
- If the front passenger airbag assembly has been found to be faulty in troubleshooting.
- If the front passenger airbag assembly, instrument panel or instrument panel reinforcement has been found to be faulty during the check in items. (See page [RS-25](#))
- If the front passenger airbag assembly has been dropped.

CAUTION:

For replacement of the front passenger airbag assembly, see page [RS-24](#) and [RS-35](#). Be sure to follow the correct procedure.

INSTALLATION

NOTICE:

Never use airbag parts from another vehicle. When replacing parts, replace them with new parts.

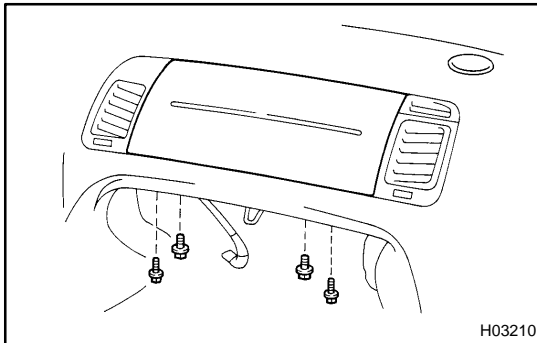

1. INSTALL FRONT PASSENGER AIRBAG ASSEMBLY

- (a) Install the front passenger airbag assembly.
- (b) Install the 2 bolts to instrument panel reinforcement.

Torque: 20 N·m (204 kgf·cm, 15 ft·lbf)

- (c) Install the 2 bolts to instrument panel.

Torque: 8.5 N·m (87 kgf·cm, 75 in·lbf)

NOTICE:

- Make sure that no foreign objects are trapped between the airbag bag, and within the module.
- Do not damage the strap when installing the module.

NOTICE:

If the front passenger airbag assembly has been dropped, or there are cracks, dents or other defects in the case or connector, replace the front passenger airbag assembly with a new one.

2. INSTALL THESE PARTS: (See page [BO-50](#))

- (a) Heater to register duct No.4
- (b) Instrument panel box

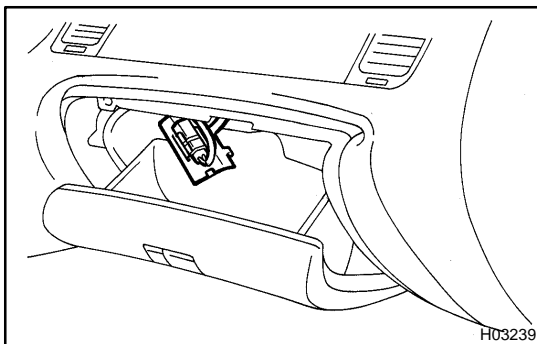

3. CONNECT AIRBAG CONNECTOR

- (a) Connect the airbag connector.
- (b) Put the connector on the glove compartment door finish plate.
- (c) Install the glove compartment door finish plate to the instrument panel box.

AIRBAG SENSOR ASSEMBLY COMPONENTS

RS06Z-01

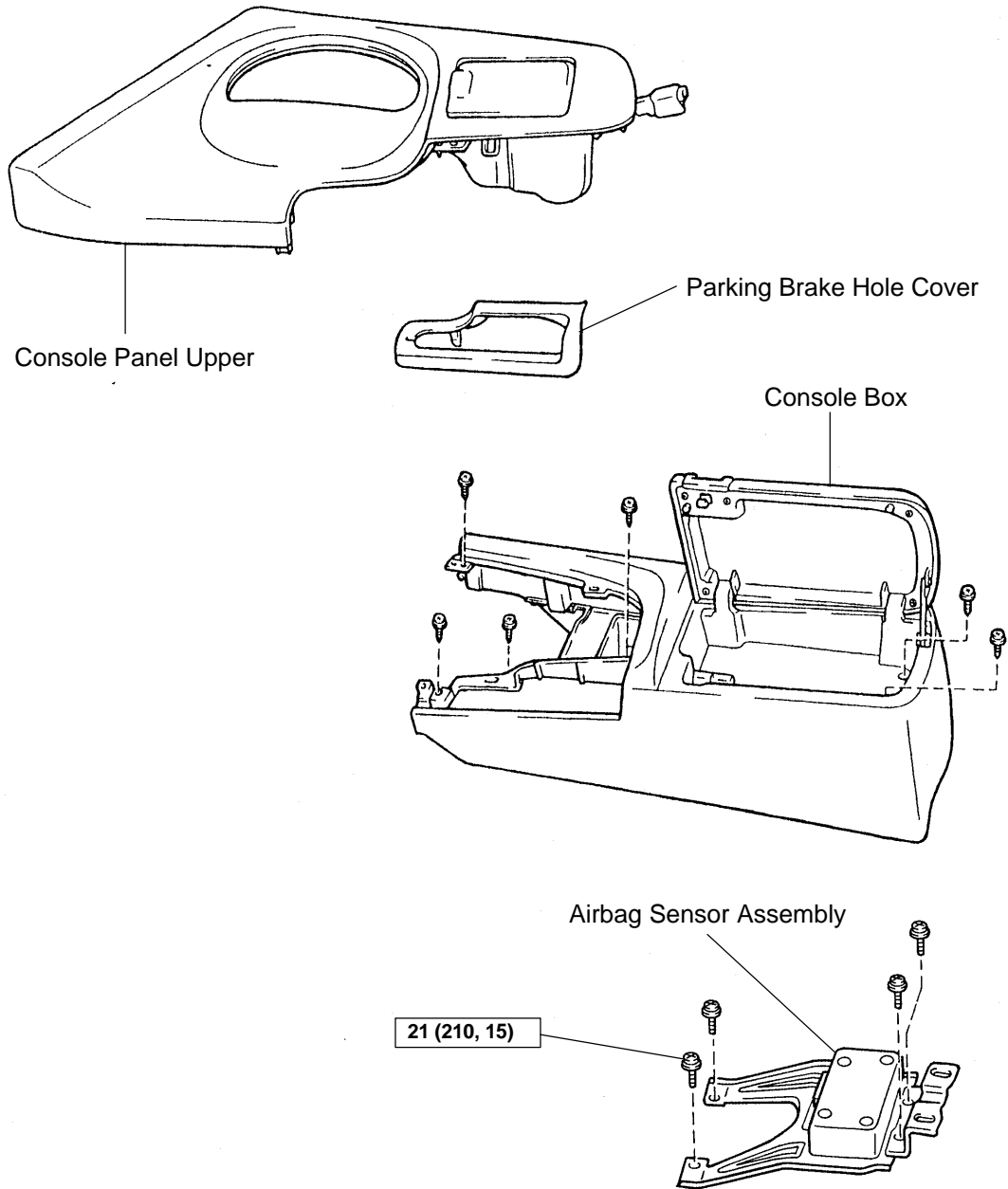

N·m (kgf·cm, ft·lbf) : Specified torque

H03811

REMOVAL

NOTICE:

Do not open the cover or the case of the ECU and various electrical devices unless absolutely necessary.

(If the IC terminals are touched, the IC may be destroyed by static electricity.)

1. REMOVE THESE PARTS

- (a) Console panel upper
- (b) Parking brake hole cover
- (c) Console box

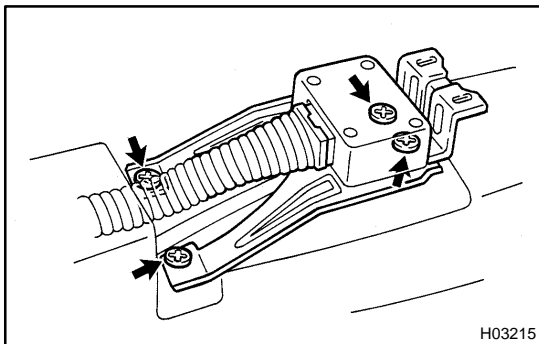

2. REMOVE AIRBAG SENSOR ASSEMBLY

- (a) Disconnect the airbag sensor connectors.

NOTICE:

Remove the connectors with the sensor assembly installed.

- (b) Using a torx wrench, remove the 4 screws and airbag sensor assembly.

Torx wrench: T40 (Part No.09042-00020 or locally manufactured tool)

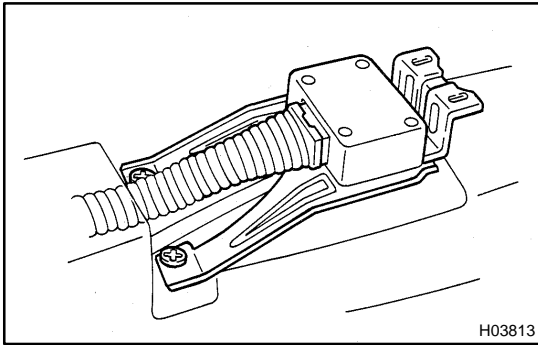

INSPECTION

1. VEHICLE NOT INVOLVED IN COLLISION

Do a diagnostic system check.

(See page [DI-589](#))

2. VEHICLE INVOLVED IN COLLISION AND AIRBAG IS NOT DEPLOYED

Do a diagnostic system check.

(See page [DI-589](#))

3. VEHICLE INVOLVED IN COLLISION AND AIRBAG IS DEPLOYED

Replace the airbag sensor assembly.

REPLACEMENT

REPLACEMENT REQUIREMENT

In the following cases, replace the airbag sensor assembly.

- If the SRS has been deployed in a collision.
- If the airbag sensor assembly has been found to be faulty in troubleshooting.
- If the airbag sensor assembly has been dropped.

CAUTION:

For removal and installation of the airbag sensor assembly, see page [RS-37](#) and [RS-40](#). Be sure to follow the correct procedure.

INSTALLATION

NOTICE:

- Never use SRS parts from another vehicle. When replacing parts, replace them with new parts.
- Never reuse the airbag sensor assembly involved in a collision when the airbag has deployed.
- Never repair a sensor in order to reuse it.

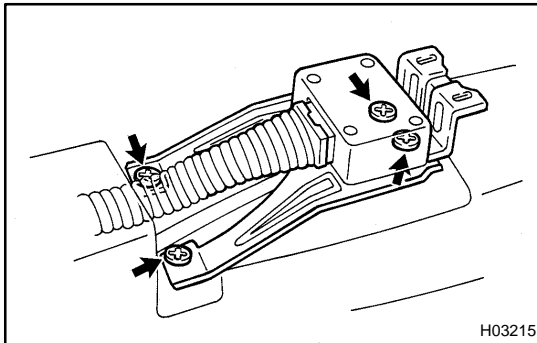

1. INSTALL AIRBAG SENSOR ASSEMBLY

- (a) Using a torx wrench, install the airbag sensor assembly with 4 screws.

Torx wrench: T40 (Part No.09042-00020 or locally manufactured tool)

Torque: 21 N·m (210 kgf·cm, 15 ft·lbf)

- (b) Connect the airbag sensor connectors.

NOTICE:

- Installation of the connector is done after the sensor assembly has been installed.
- Make sure the sensor assembly is installed with the specified torque.
- If the sensor assembly has been dropped, or there are cracks, dents or other defects in the case, bracket or connector, replace the sensor assembly with a new one.
- When installing the sensor assembly, take care that the SRS wiring does not interfere with other parts and is not pinched between other parts.
- After installing, shake the sensor assembly to check that there is no looseness.

2. INSTALL THESE PARTS:

- (a) Console box
 (b) Parking brake hole cover
 (c) Console panel upper

WIRE HARNESS AND CONNECTOR LOCATION

RS074-01

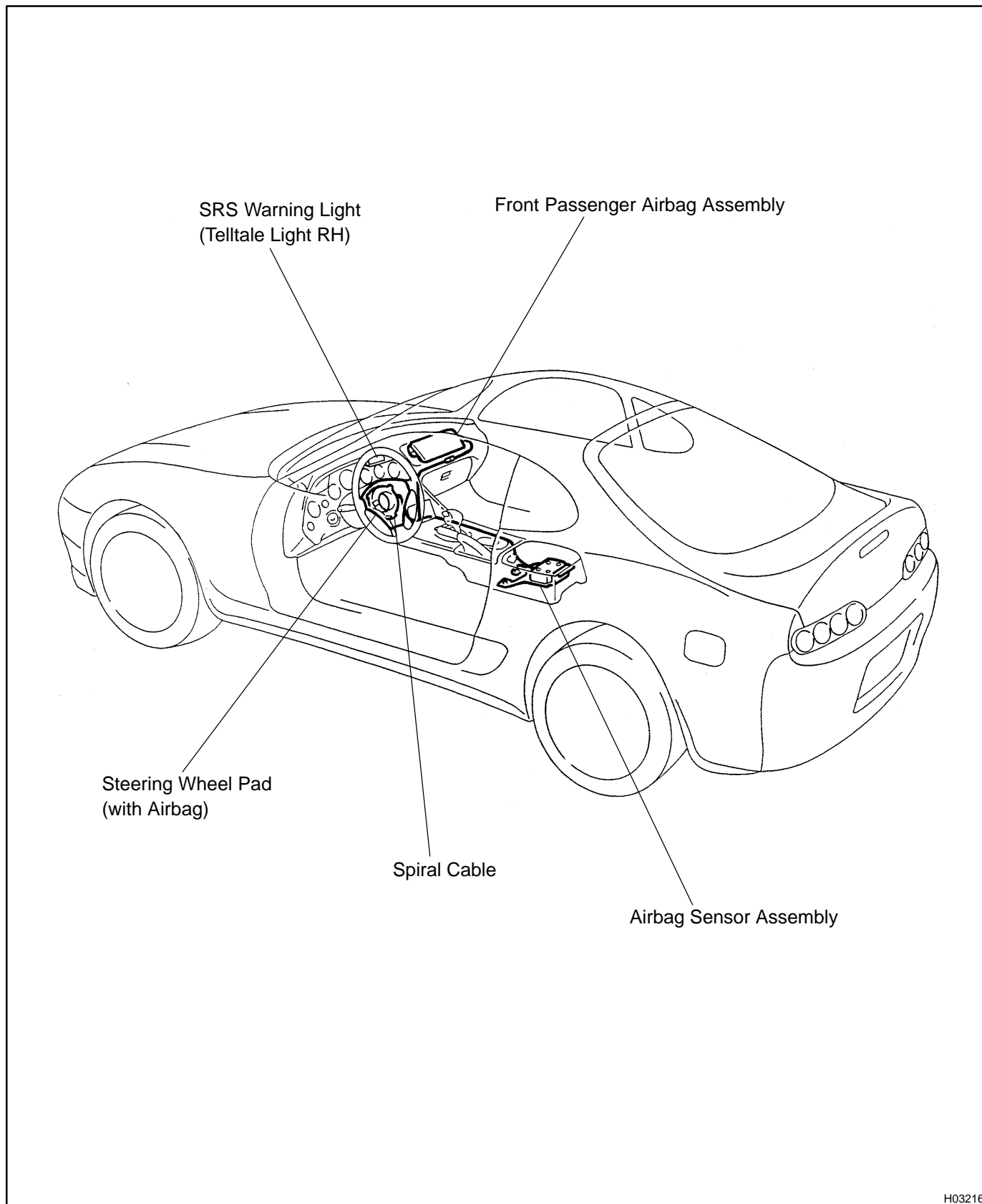

H03216

INSPECTION

HINT:

The SRS wire harness is integrated with the instrument panel wire harness assembly. The wires for the SRS wire harness are encased in a yellow corrugated tube and all the connectors in the system are a standard yellow color.

1. VEHICLES NOT INVOLVED IN COLLISION

Do a diagnostic system check.

(See page [DI-589](#))

2. VEHICLES INVOLVED IN COLLISION

(a) Do a diagnostic system check.

(See page [DI-589](#))

(b) Check breaks in all wires of the SRS wire harness, and exposed conductors.

(c) Check to see if the SRS wire harness connectors are cracked or chipped.

REPLACEMENT

In the following cases, replace the wire harness or connector.

- If any part of the SRS wire harness or any connector has been found to be faulty in troubleshooting.
- If any part of the SRS wire harness or any connector has been found to be faulty during the checking items. (See page [RS-42](#))

CAUTION:

If the wire harness used in the SRS is damaged, replace the whole wire harness assembly.