

OUTSIDE VEHICLE

GENERAL MAINTENANCE

MA01D-01

These are maintenance and inspection items which are considered to be the owner's responsibility. They can be done by the owner or they can have them done at a service shop.

These items include those which should be checked on a daily basis, those which, in most cases, do not require (special) tools and those which are considered to be reasonable for the owner to do.

Items and procedures for general maintenance are as follows.

1. GENERAL NOTES

- Maintenance items may vary from country to country. Check the owner's manual supplement in which the maintenance schedule is shown.
- Every service item in the periodic maintenance schedule must be performed.
- Periodic maintenance service must be performed according to whichever interval in the periodic maintenance schedule occurs first, the odometer reading (miles) or the time interval (months).
- Maintenance service after the last period should be performed at the same interval as before unless otherwise noted.
- Failure to do even one item can cause the engine to run poorly and increase exhaust emissions.

2. TIRES

- (a) Check the pressure with a gauge. If necessary, adjust.
- (b) Check for cuts, damage, uneven or excessive wear.

3. WHEEL NUTS

When checking the tires, check the nuts for looseness or for missing nuts. If necessary, tighten them.

4. WINDSHIELD WIPER BLADES

Check for wear or cracks whenever they do not wipe clean. If necessary, replace.

5. FLUID LEAKS

- (a) Check underneath for leaking fuel, oil, water or other fluid.
- (b) If you smell gasoline fumes or notice any leak, have the cause found and corrected.

6. DOORS AND ENGINE HOOD

- (a) Check that all doors and the tailgate operate smoothly, and that all latches lock securely.
- (b) Check that the engine hood secondary latch secures the hood from opening when the primary latch is released.

INSIDE VEHICLE

MA01E-01

GENERAL MAINTENANCE

These are maintenance and inspection items which are considered to be the owner's responsibility.

They can be done by the owner or they can have them done at a service shop.

These items include those which should be checked on a daily basis, those which, in most cases, do not require (special) tools and those which are considered to be reasonable for the owner to do.

Items and procedures for general maintenance are as follows.

1. GENERAL NOTES

- Maintenance items may vary from country to country. Check the owner's manual supplement in which the maintenance schedule is shown.
- Every service item in the periodic maintenance schedule must be performed.
- Periodic maintenance service must be performed according to whichever interval in the periodic maintenance schedule occurs first, the odometer reading (miles) or the time interval (months).
- Maintenance service after the last period should be performed at the same interval as before unless otherwise noted.
- Failure to do even one item can cause the engine to run poorly and increase exhaust emissions.

2. LIGHTS

- (a) Check that the headlights, stop lights, taillights, turn signal lights, and other lights are all working.
- (b) Check the headlight aim.

3. WARNING LIGHTS AND BUZZERS

Check that all warning lights and buzzers function properly.

4. HORN

Check that it is working.

5. WINDSHIELD GLASS

Check for scratches, pits or abrasions.

6. WINDSHIELD WIPER AND WASHER

- (a) Check operation of the wipers and washer.
- (b) Check that the wipers do not streak.

7. WINDSHIELD DEFROSTER

Check that air comes out from the defroster outlet when operating the heater or air conditioner.

8. REAR VIEW MIRROR

Check that it is mounted securely.

9. SUN VISORS

Check that they move freely and are mounted securely.

10. STEERING WHEEL

Check that it has the specified freeplay. Be alert for changes in steering condition, such as hard steering, excessive freeplay or strange noises.

11. SEATS

- (a) Check that the seat adjusters operate smoothly.
- (b) Check that all latches lock securely in any position.
- (c) Check that the head restraints move up and down smoothly and that the locks hold securely in any latch position.
- (d) For fold-down seat backs, check that the latches lock securely.

12. SEAT BELTS

- (a) Check that the seat belt system such as the buckles, retractors and anchors operate properly and smoothly.
- (b) Check that the belt webbing is not cut, frayed, worn or damaged.

13. ACCELERATOR PEDAL

Check the pedal for smooth operation and uneven pedal effort or catching.

14. CLUTCH PEDAL (See page CL-2)

- (a) Check the pedal for smooth operation.
- (b) Check that the pedal has the proper freeplay.

15. BRAKE PEDAL (See page BR-7)

- (a) Check the pedal for smooth operation.
- (b) Check that the pedal has the proper reserve distance and freeplay.
- (c) Check the brake booster function.

16. BRAKES

At a safe place, check that the brakes do not pull to one side when applied.

17. PARKING BRAKE (See page BR-9)

- (a) Check that the lever has the proper travel.
- (b) On a safe incline, check that the vehicle is held securely with only the parking brake applied.

18. AUTOMATIC TRANSMISSION "PARK" MECHANISM

- (a) Check the lock release button of the selector lever for proper and smooth operation.
- (b) On a safe incline, check that the vehicle is held securely with the selector lever in "P" position and all brakes released.

UNDER HOOD

MA01F-01

GENERAL MAINTENANCE

1. GENERAL NOTES

- Maintenance items may vary from country to country. Check the owner's manual supplement in which the maintenance schedule is shown.
- Every service item in the periodic maintenance schedule must be performed.
- Periodic maintenance service must be performed according to whichever interval in the periodic maintenance schedule occurs first, the odometer reading (miles) or the time interval (months).
- Maintenance service after the last period should be performed at the same interval as before unless otherwise noted.
- Failure to do even one item can cause the engine to run poorly and increase exhaust emissions.

2. WINDSHIELD WASHER FLUID

Check that there is sufficient fluid in the tank.

3. ENGINE COOLANT LEVEL

Check that the coolant level is between the "FULL" and "LOW" lines on the see-through reservoir.

4. RADIATOR AND HOSES

- (a) Check that the front of the radiator is clean and not blocked with leaves, dirt or bugs.
- (b) Check the hoses for cracks, kinks, rot or loose connections.

5. BATTERY ELECTROLYTE LEVEL

Check that the electrolyte level of all battery cells is between the upper and lower level lines on the case.

6. BRAKE AND CLUTCH FLUID LEVELS

Check that the brake and clutch fluid levels are near the upper level line on the see-through reservoirs.

7. ENGINE DRIVE BELT

Check drive belt for fraying, cracks, wear or oil contamination.

8. ENGINE OIL LEVEL

Check the level on the dipstick with the engine turned off.

9. POWER STEERING FLUID LEVEL

- Check the level on the dipstick.
- The level should be in the "HOT" or "COLD" range depending on the fluid temperature.

10. AUTOMATIC TRANSMISSION FLUID LEVEL

- (a) Park the vehicle on a level surface.
- (b) With the engine idling and the parking brake applied, shift the selector into all positions from "P" to "L", and then shift into "P" position.
- (c) Pull out the dipstick and wipe off the fluid with a clean rag. Re-insert the dipstick and check that the fluid level is in the HOT range.
- (d) Do this check with the fluid at normal driving temperature (70 – 80°C, 158 – 176°F).

HINT:

Wait until the engine cools down (approx. 30 min.) before checking the fluid level after extended driving at high speeds, in hot weather, in heavy traffic or pulling a trailer.

11. EXHAUST SYSTEM

If any change in the sound of the exhaust or smell of the exhaust fumes is noticed, have the cause located and corrected.

ENGINE INSPECTION

MA01G-01

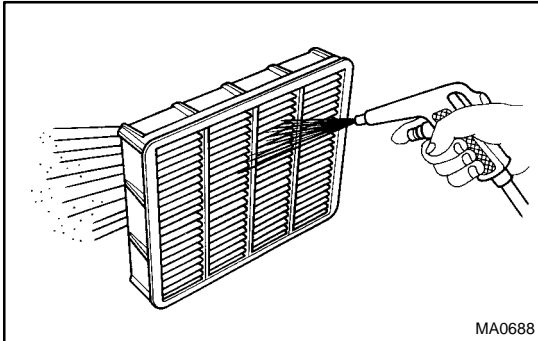

1. **REPLACE TIMING BELT**
(2JZ-GE: See page [EM-19](#))
(2JZ-GTE: See page [EM-19](#))
2. **INSPECT DRIVE BELT**
(See page [CH-2](#))
3. **REPLACE SPARK PLUGS**
(2JZ-GE: See page [IG-1](#))
(2JZ-GTE: See page [IG-1](#))
4. **INSPECT AIR FILTER**
 - (a) Remove the air filter.
 - (b) Visually check that the air filter is not excessively damaged or oily.

If necessary, replace the air filter.

 - (c) Clean the filter with compressed air.
First blow from the inside thoroughly, then blow off the outside of the filter.
 - (d) Reinstall the air filter and air cleaner case.
5. **REPLACE AIR FILTER**
Replace the air filter with a new one.
6. **REPLACE ENGINE OIL AND OIL FILTER**
(See page [LU-3](#))
7. **REPLACE ENGINE COOLANT**
(See page [CO-2](#))
8. **INSPECT CHARCOAL CANISTER**
(2JZ-GE: See page [EC-5](#))
(2JZ-GTE: See page [EC-5](#))
9. **REPLACE GASKET IN FUEL TANK CAP**
(2JZ-GE: See page [EC-5](#))
(2JZ-GTE: See page [EC-5](#))
10. **INSPECT FUEL LINES AND CONNECTIONS**
(2JZ-GE: See page [SF-28](#))
(2JZ-GTE: See page [SF-34](#))
11. **INSPECT EXHAUST PIPES AND MOUNTINGS**
Visually check the pipes, hangers and connections for severe corrosion, leaks or damages.
12. **ADJUST VALVE CLEARANCE**
(2JZ-GE: See page [EM-4](#))
(2JZ-GTE: See page [EM-4](#))

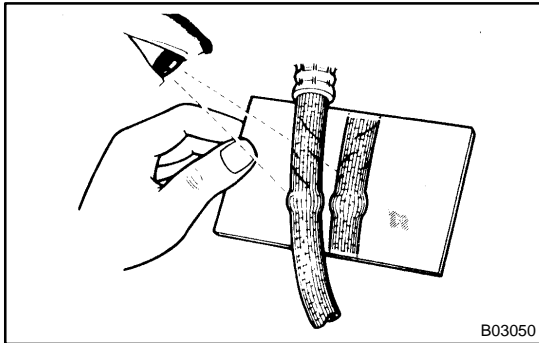

BRAKE INSPECTION

MA01H-01

1. INSPECT BRAKE LINE PIPES AND HOSES

HINT:

Check in a well lighted area. Check the entire circumference and length of the brake hoses using a mirror as required. Turn the front wheels fully right or left before checking the front brake.

- (a) Check all brake lines and hoses for:
 - Damage
 - Wear
 - Deformation
 - Cracks
 - Corrosion
 - Leaks
 - Bends
 - Twists
- (b) Check all clamps for tightness and connections for leakage.
- (c) Check that the hoses and lines are clear of sharp edges, moving parts and the exhaust system.
- (d) Check that the lines installed in grommets pass through the center of the grommets.

2. INSPECT FRONT AND REAR BRAKE PADS AND DISCS

2JZ-GE:

Front: See page [BR-23](#)

Rear: See page [BR-43](#)

2JZ-GTE:

Front: See page [BR-26](#)

Rear: See page [BR-46](#)

HINT:

If a squealing or scraping noise comes from the brake during driving, check the pad wear indicator to see if it is contacting the disk rotor. If so, the disk pad should be replaced.

3. INSPECT PARKING BRAKE LININGS AND DRUMS (See page [BR-62](#))

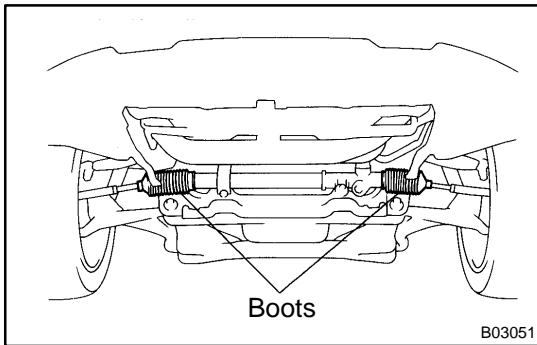

CHASSIS INSPECTION

MA01-01

1. INSPECT STEERING LINKAGE

- (a) Check the steering wheel freeplay.
(See page [SR-9](#))
- (b) Check the steering linkage for looseness or damage.
Check that:
 - Tie rod ends do not have excessive play.
 - Dust seals and boots are not damaged.
 - Boot clamps are not loose.

2. INSPECT SRS AIRBAG (See page [RS-11](#))

3. INSPECT STEERING GEAR HOUSING OIL

Check the steering gear housing for oil leakage.

4. INSPECT BALL JOINT DUST COVERS

Visually check the dust covers for damage.

5. INSPECT TRANSMISSION OIL (FLUID) AND DIFFERENTIAL OIL

- (a) Visually check the transmission and differential for oil (fluid) leakage.

If leakage is found, check for the cause and repair it.

6. REPLACE MANUAL TRANSMISSION OIL (See page [MT-3](#))

7. REPLACE AUTOMATIC TRANSMISSION FLUID
(2JZ-GE: See page [AT-2](#))
(2JZ-GTE: See page [AT-2](#))

8. REPLACE DIFFERENTIAL OIL (See page [SA-61](#))

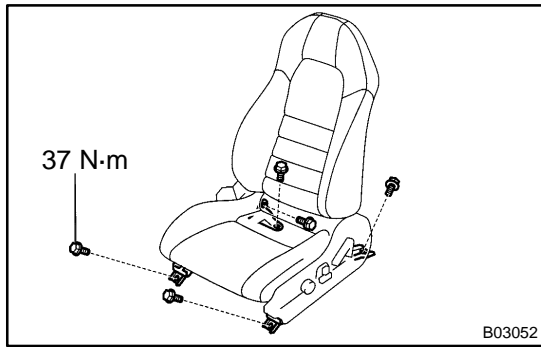

BODY INSPECTION

1. TIGHTEN BOLTS AND NUTS ON CHASSIS AND BODY

Tighten these parts:

- Front seat – to –body mounting bolts

Torque: 37 N·m (375 kgf-cm, 27 ft-lbf)

- Front suspension member–to–body mounting nuts

Torque:

Front side 125 N·m (1,280kgf-cm,92 ft-lbf)

Rear side 200 N·m (2,040 kgf-cm,148ft-lbf)

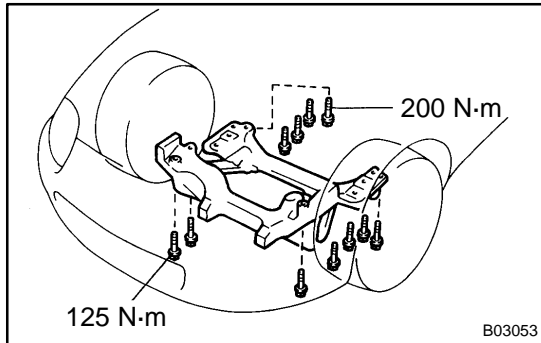

- Rear suspension member–to–body mounting bolts

Torque: 175 N·m (1,790 kgf-cm, 129 ft-lbf)

- Rear suspension member rear cushion – to – body mounting bolts

Torque: 58 N·m (590 kgf-cm, 43 ft-lbf)

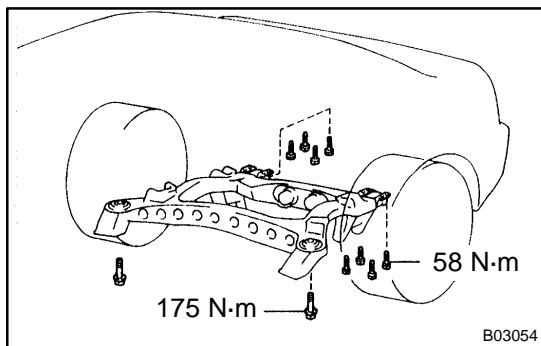

2. FINAL INSPECTION

(a) Check the operation of the body parts:

- Hood:
 - Auxiliary catch operate properly
 - Hood locks securely when closed
- Front doors:
 - Door lock operates properly
 - Doors close properly
- Back door:
 - Door lock operates properly
- Seats:
 - Seat adjusts easily and locks securely in any position
 - Front seat back locks securely in any position
 - Folding-down rear seat backs lock securely

(b) Road test:

- Check the engine and chassis for abnormal noises.
- Check that the vehicle does not wander or pull to one side.
- Check that the brake work properly and do not drag.
- Perform setting of the parking brake shoes and disc.

- (c) Be sure to deliver a clean car. especially check:
- Steering wheel
 - Shift lever knob
 - All switch knobs
 - Seats