

# EMISSION CONTROL SYSTEM

EC042-01

## PURPOSE

The emission control systems are installed to reduce the amount of CO, HC and NOx exhausted from the engine ((3), (4) and (5)), to prevent the atmospheric release of blow-by gas-containing HC (1) and evaporated fuel containing HC being released from the fuel tank (2).

The function of each system is shown in these table.

System	Abbreviation	Function
(1) Positive Crankcase Ventilation	PCV	Reduces HC
(2) Evaporative Emission Control	EVAP	Reduces evaporated HC
(3) Exhaust Gas Recirculation	EGR	Reduces NOx
(4) Three-Way Catalytic Converter	TWC	Reduces CO, HC and NOx
(5) Sequential Multiport Fuel Injection *	SFI	Injects a precisely timed, optimum amount of fuel for reduced exhaust emissions

Remark: \* For inspection and repair of the SFI system, refer to the SFI section this manual.

# PARTS LAYOUT AND SCHEMATIC DRAWING LOCATION

EC043-01

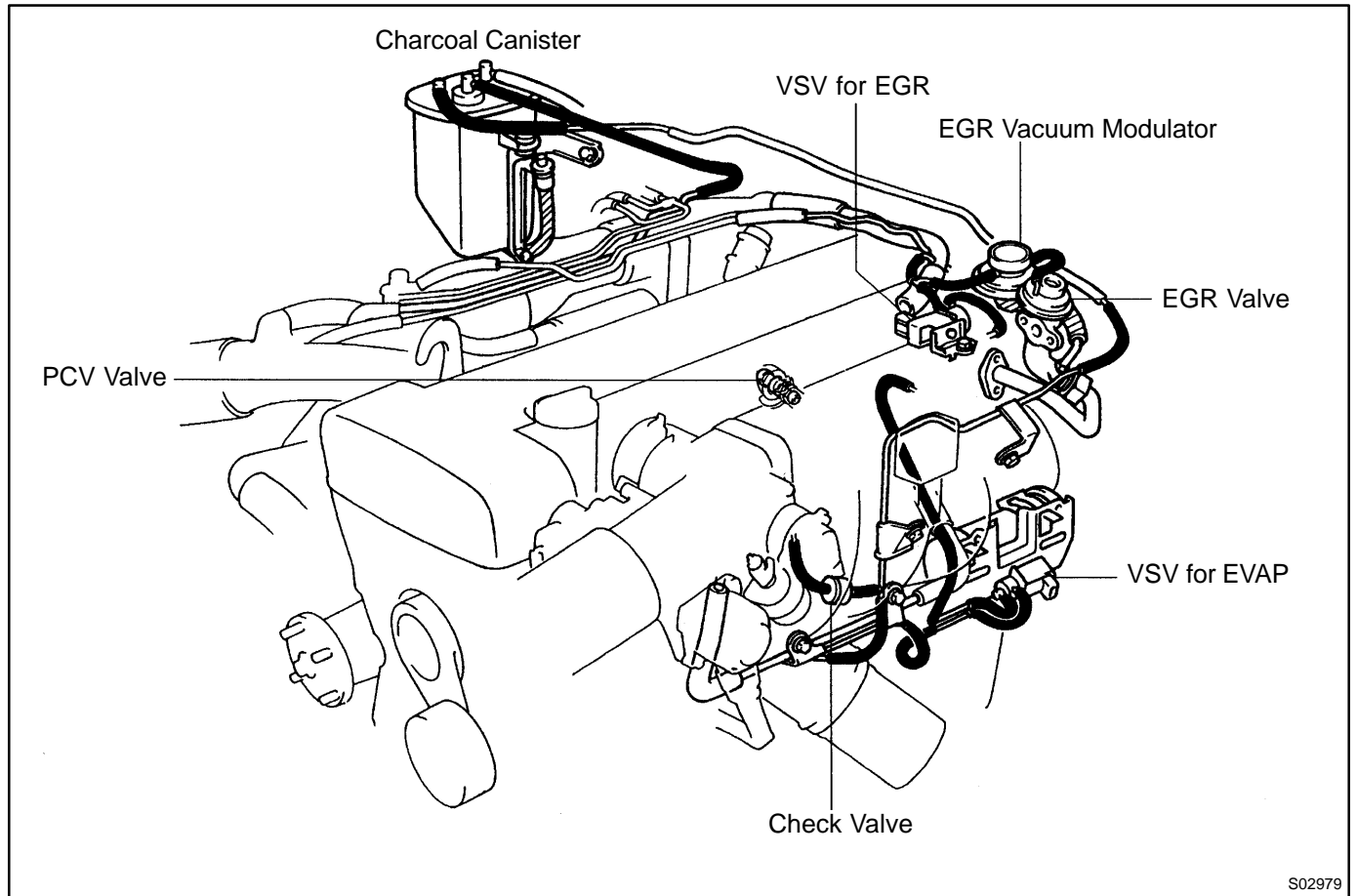

S02979

DRAWING

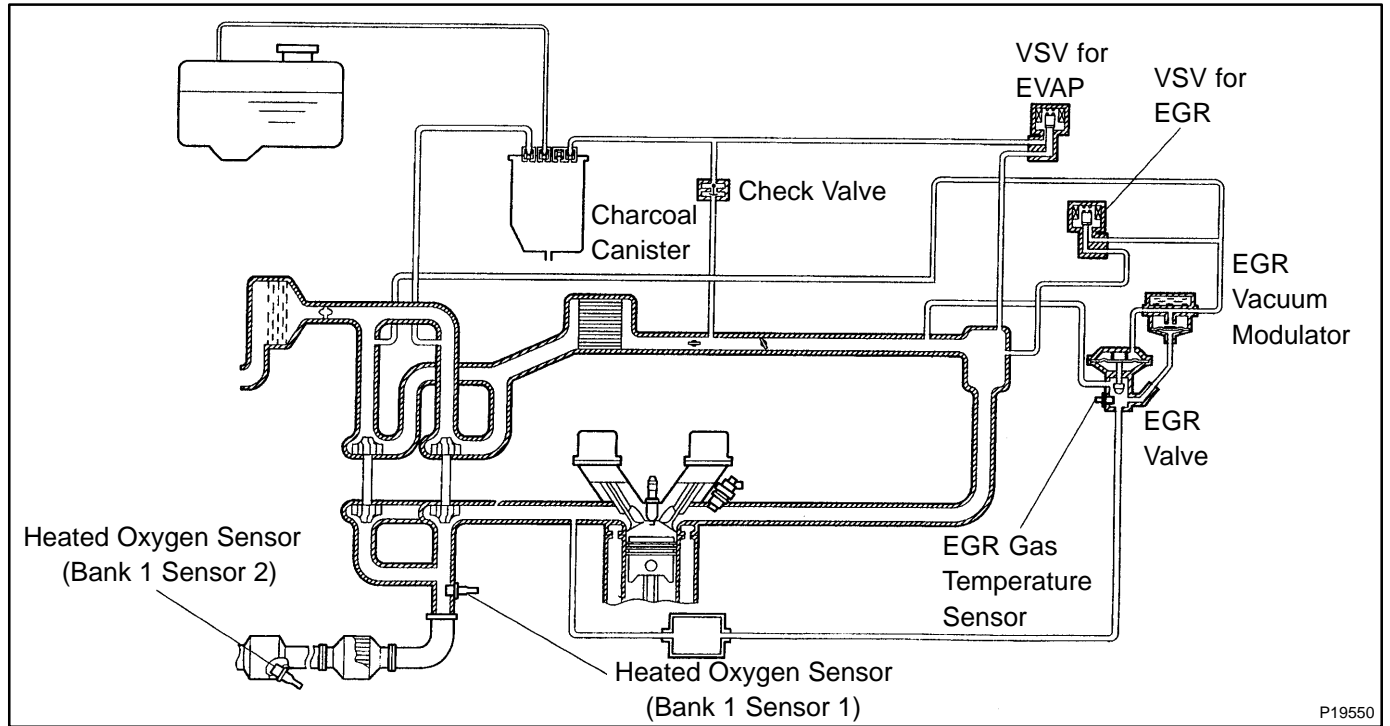

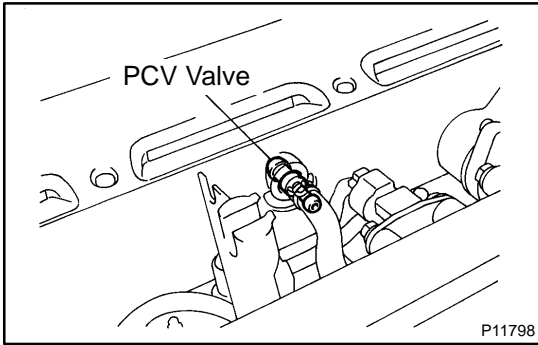

# POSITIVE CRANKCASE VENTILATION (PCV) SYSTEM INSPECTION

EC045-01

1. **REMOVE PCV VALVE**
  - (a) Disconnect the PCV hose from the PCV valve.
  - (b) Remove the PCV valve.

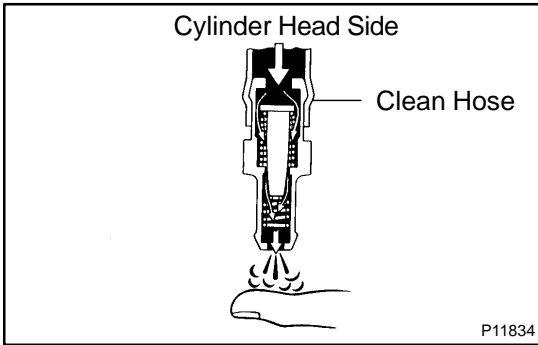

2. **INSTALL CLEAN HOSE TO PCV VALVE**
3. **INSPECT PCV VALVE OPERATION**
  - (a) Blow air into the cylinder head side, and check that air passes through easily.

**CAUTION:**

- ◆ Do not suck air through the valve.
- ◆ Petroleum substances inside the valve are harmful.

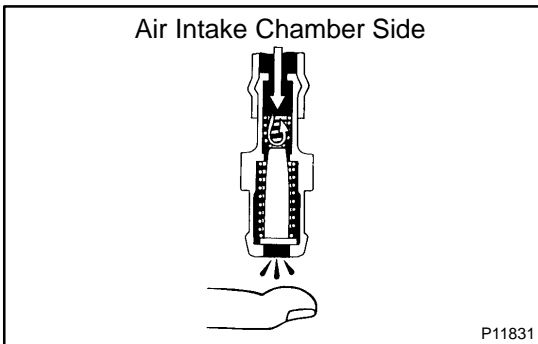

- (b) Blow air into the air intake chamber side, and check that air passes through with difficulty.
- If operation is not as specified, replace the PCV valve.

4. **REMOVE CLEAN HOSE FROM PCV VALVE**
5. **REINSTALL PCV VALVE**

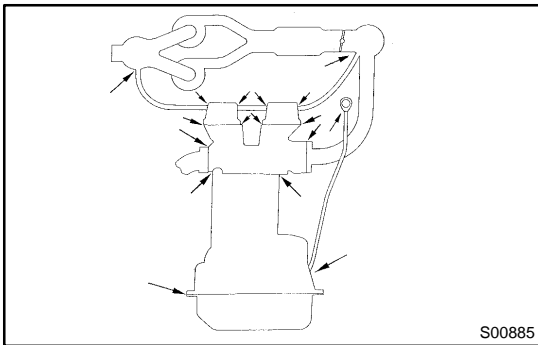

6. **VISUALLY INSPECT HOSES, CONNECTIONS AND GASKETS**  
Check for cracks, leaks or damage.

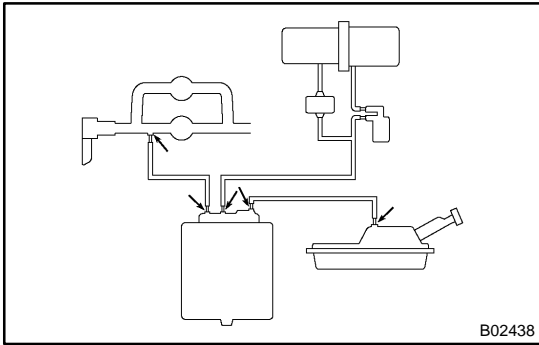

# EVAPORATIVE EMISSION (EVAP) CONTROL SYSTEM INSPECTION

EC046-01

## 1. VISUALLY INSPECT LINES AND CONNECTIONS

Look for loose connections, sharp bends or damage.

## 2. VISUALLY INSPECT FUEL TANK

Look for deformation, cracks or fuel leakage.

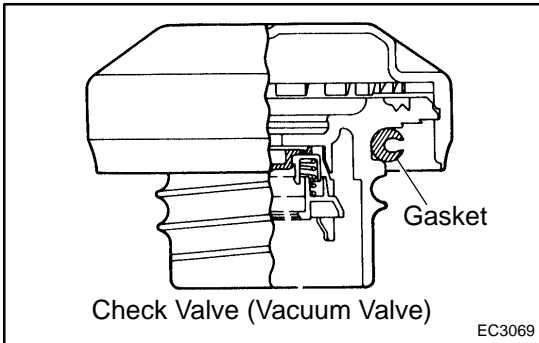

## 3. VISUALLY INSPECT FUEL TANK CAP

Check if the cap and/or gasket are deformed or damaged.

If necessary, repair or replace the cap.

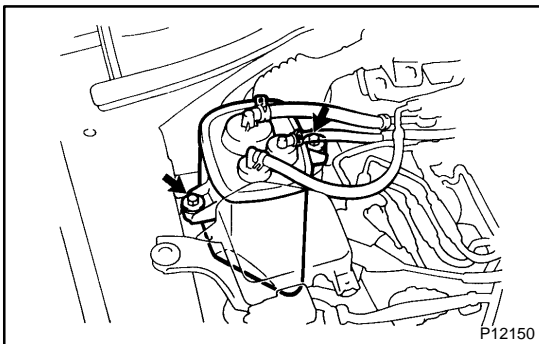

## 4. REMOVE CHARCOAL CANISTER

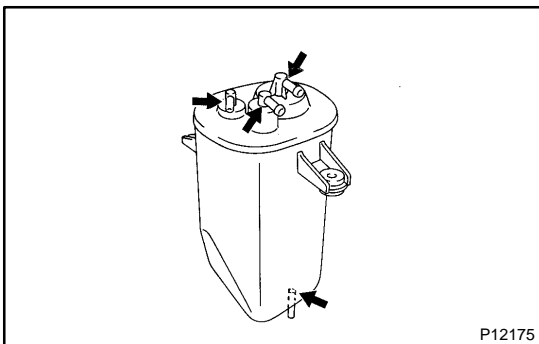

## 5. VISUALLY INSPECT CHARCOAL CANISTER

Look for cracks or damage.

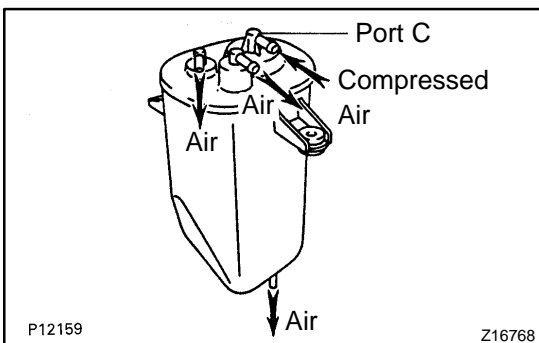

## 6. CHECK FOR CLOGGED FILTER AND STUCK CHECK VALVE

- (a) Using low pressure compressed air (4.71 kPa (48 gf/cm<sup>2</sup>, 0.68 psi)), blow into port C and check that air flows without resistance from the other ports.

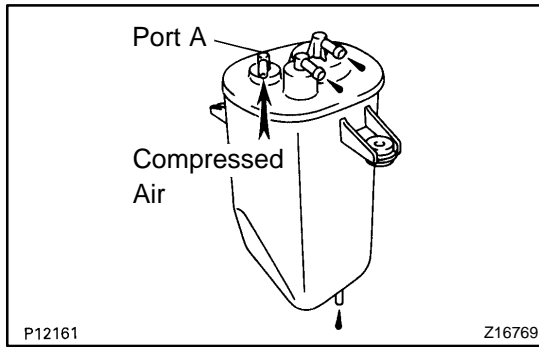

(b) Blow air (4.71 kPa (48 gf/cm<sup>2</sup>, 0.68 psi)) into port A, and check that air does not flow from the other ports.

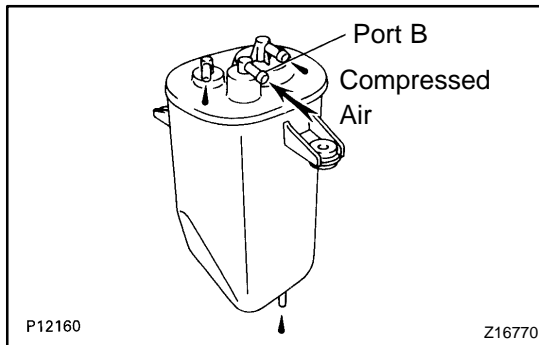

(c) Blow air (4.71 kPa (48 gf/cm<sup>2</sup>, 0.68 psi)) into port B, and check that air does not flow from the other ports.  
If operation is not as specified, replace the charcoal canister.

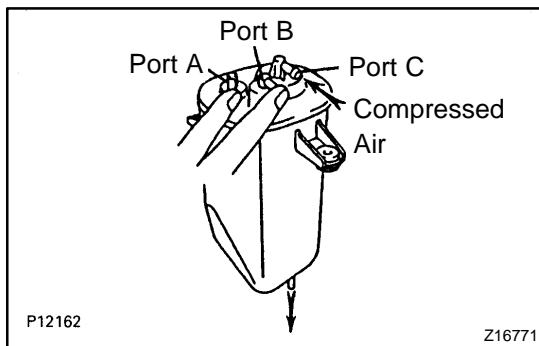

**7. CLEAN FILTER IN CANISTER**

Clean the filter by blowing 294 kPa (3 kgf/cm<sup>2</sup>, 43 psi) of compressed air into port C while holding port A and B closed.

**NOTICE:**

- ◆ Do not attempt to wash the canister.
- ◆ No activated carbon should come out.

**8. REINSTALL CHARCOAL CANISTER**

**9. INSPECT VSV FOR EVAP**  
(See page SF-71)

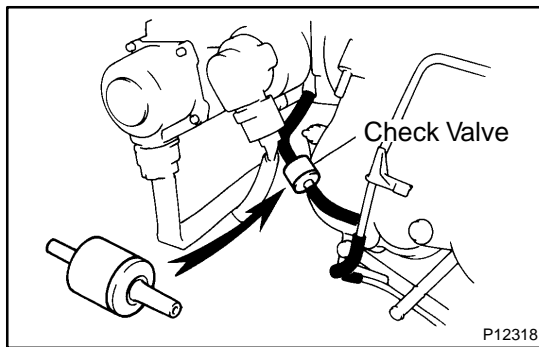

**10. REMOVE CHECK VALVE**

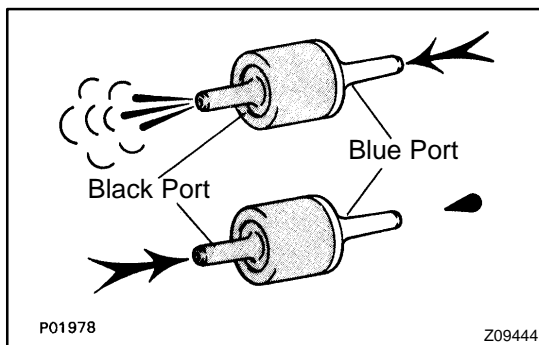

**11. INSPECT CHECK VALVE**

- (a) Check that air flows from the blue port to the black port.
- (b) Check that air does not flow from the black port to the blue port.

If operation is not as specified, replace the check valve.

**12. REINSTALL CHECK VALVE**

**HINT:**

Install the check valve with the black port facing the purge port side of the throttle body.

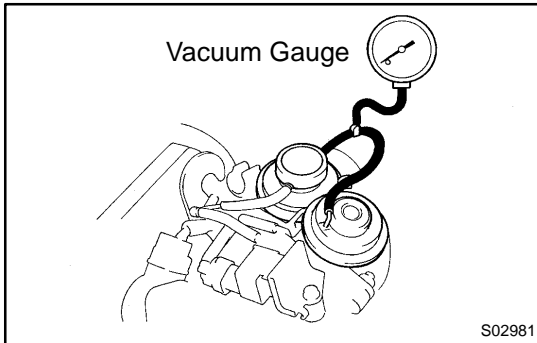
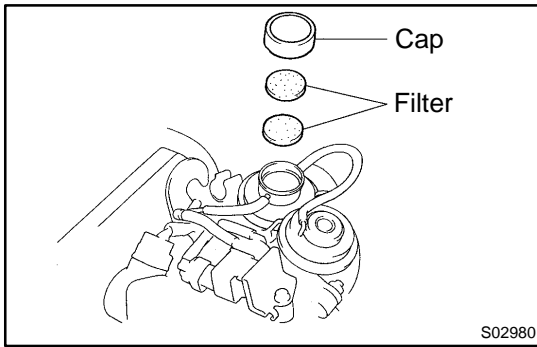

## EXHAUST GAS RECIRCULATION (EGR) SYSTEM INSPECTION

EC047-01

### 1. CHECK AND CLEAN FILTER IN EGR VACUUM MODULATOR

- (a) Remove the cap and 2 filters.
- (b) Check the filter for contamination or damage.
- (c) Using compressed air, clean the filter.
- (d) Reinstall the 2 filters and cap.

#### HINT:

Install the filter with the coarser surface facing the atmospheric side (outward).

### 2. INSTALL VACUUM GAUGE

Using a 3-way connector, connect a vacuum gauge to the hose between the EGR valve and EGR vacuum modulator.

### 3. INSPECT SEATING OF EGR VALVE

Start the engine and check that the engine starts and runs at idle.

### 4. INSPECT VSV OPERATION WITH COLD ENGINE

- (a) M/T

The coolant temperature should be below 65°C (149°F).

- (1) Start the engine and check idling.
- (2) When idling with the lever shifting in the N position, press accelerator pedal slowly to hold the engine speed at 3,500 – 4,000 rpm with the throttle opening about (one third) 1/3.
- (3) Check that the vacuum gauge indicates zero.

- (b) A/T

The coolant temperature should be below 50°C (122°F).

- (1) Chock the 4 wheels.
- (2) Fully apply the parking brake.
- (3) Connect a tachometer to the engine.
- (4) Start the engine and check idle.
- (5) Keep your foot pressed firmly on the brake pedal.
- (6) Shift into the D position. Press the accelerator pedal slowly to hold the engine speed at 1,600 – 1,800 rpm.
- (7) Check that the vacuum gauge indicates zero.

### 5. INSPECT VSV OPERATION WITH HOT ENGINE

- (a) M/T

Warm up the engine. The coolant temperature in 65°C (149°F) or more.

- (1) When idling with the lever shifting in the N position, press accelerator pedal slowly to hold the engine speed at 3,500 – 4,000 rpm with the throttle opening about (one third) 1/3.
- (2) Check that the vacuum gauge indicates low vacuum momentarily.

- (b) A/T
  - Warm up the engine. The coolant temperature in 50°C (122°F) or more.
  - (1) Chock the 4 wheels.
  - (2) Fully apply the parking brake.
  - (3) Connect a tachometer to the engine.
  - (4) Start the engine and check idling.
  - (5) Keep your foot pressed firmly on the brake pedal.
  - (6) Shifting into the D position. Press the accelerator pedal slowly to hold the engine speed at 1,600 – 1,800 rpm.
  - (7) Check that the vacuum gauge indicates low vacuum.

**6. REMOVE VACUUM GAUGE**

Remove the vacuum gauge, and reconnect the vacuum hoses to their proper locations.

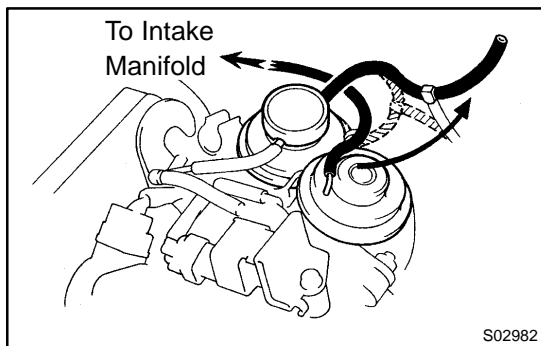

**7. INSPECT EGR VALVE**

- (a) Apply vacuum directly to the EGR valve with the engine idling.
  - (b) Check that the engine runs rough or dies.
  - (c) Reconnect the vacuum hoses to their proper locations.
- If no problem is found during this inspection, system is normal; otherwise inspect each part.

**8. INSPECT VSV FOR EGR**  
(See page SF-69)

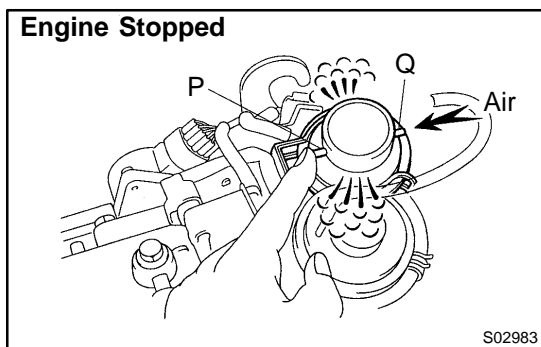

**9. DISCONNECT VACUUM HOSES FROM EGR VACUUM MODULATOR**

Disconnect the 2 vacuum hoses from ports P and Q of the EGR vacuum modulator.

**10. INSPECT EGR VACUUM MODULATOR OPERATION**

- (a) Block port P with your finger.
- (b) Blow air into port Q, and check that air passes through to the air filter side freely.

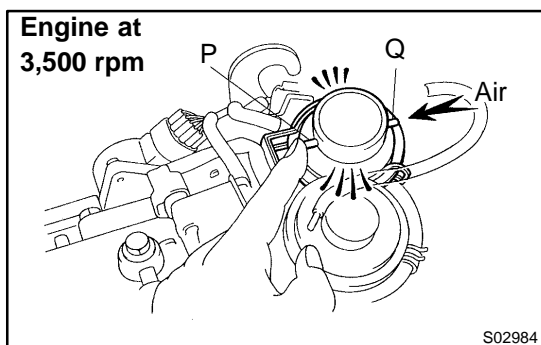

- (c) Start the engine, and maintain speed at 3,500 rpm.
- (d) Repeat the above test. Check that there is a strong resistance to air flow.

**11. RECONNECT VACUUM HOSES TO EGR VACUUM MODULATOR**

Reconnect the 2 vacuum hoses to the proper locations.

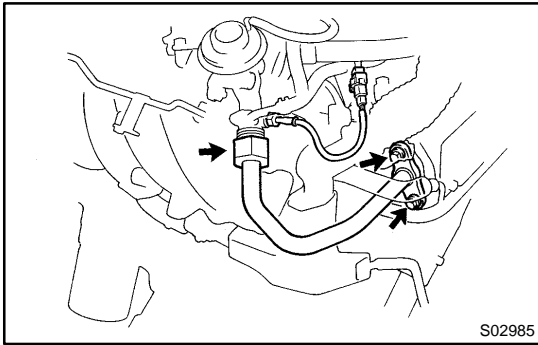

**12. REMOVE EGR PIPE**

- (a) Loosen the union nut of the EGR pipe.
- (b) Remove the 2 bolts, EGR pipe and gasket.

**13. REMOVE EGR GAS TEMPERATURE SENSOR**

**14. REMOVE EGR VALVE**

- (a) Disconnect these hoses from the EGR valve:
  - ◆ Vacuum hose
  - ◆ Pressure hose

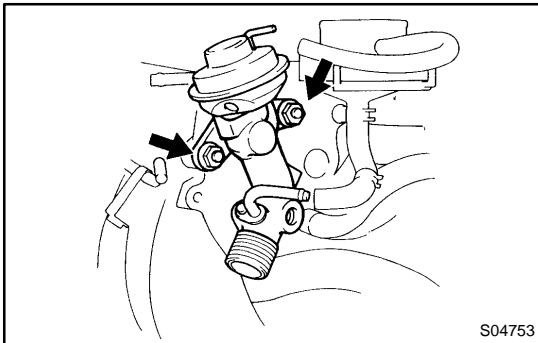

- (b) Remove the 2 nuts, EGR valve and gasket.

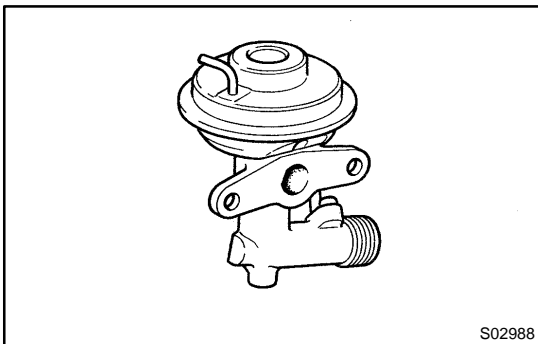

**15. INSPECT EGR VALVE**

Check for sticking and heavy carbon deposits.  
If a problem is found, replace the EGR valve.

**16. REINSTALL EGR VALVE**

- (a) Place a new gasket on the air intake chamber.
- (b) Install the EGR valve with the 2 nuts.

**Torque: 21 N·m (210 kgf-cm, 15 ft-lbf)**

- (c) Reconnect these hoses to the EGR valve:
  - ◆ Vacuum hose
  - ◆ Pressure hose

**17. REINSTALL EGR GAS TEMPERATURE SENSOR**

**Torque: 20 N·m (200 kgf-cm, 14 ft-lbf)**

**18. REINSTALL EGR PIPE**

- (a) Temporarily install the union nut of the EGR pipe.
- (b) Install a new gasket and the EGR pipe with the 2 bolts.

**Torque: 28 N·m (280 kgf-cm, 21 ft-lbf)**

- (c) Tighten the union nut of the EGR pipe.

**Torque: 65 N·m (650 kgf-cm, 48 ft-lbf)**



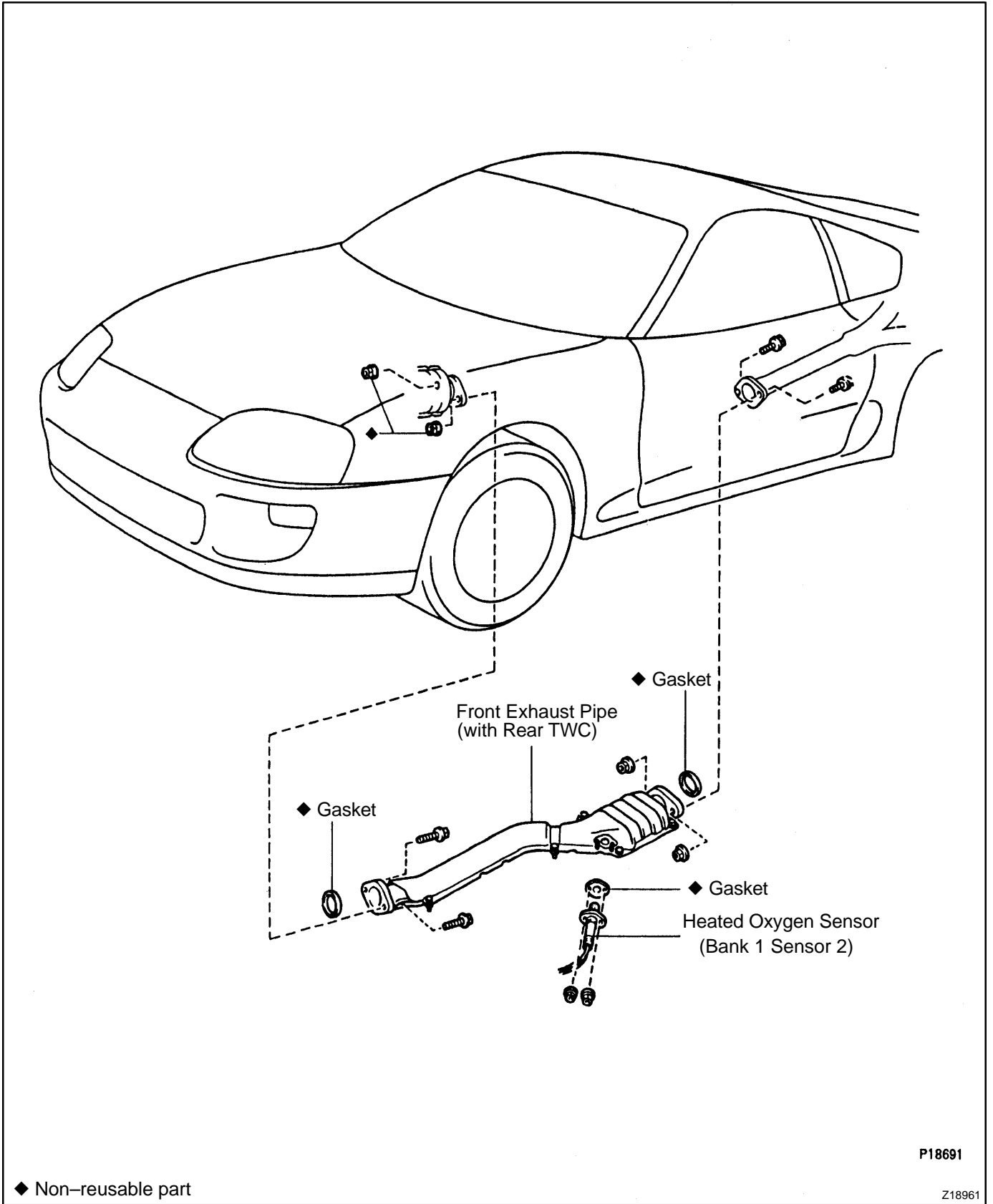

P18691

Z18961

◆ Non-reusable part

## INSPECTION

1. **CHECK CONNECTIONS FOR LOOSENESS OR DAMAGE**
2. **CHECK CLAMPS FOR WEAKNESS, CRACKS OR DAMAGE**
3. **CHECK FOR DENTS OR DAMAGE**

If any part of the protector is damaged or dented to the extent that it contacts the TWC, repair or replace it.

4. **CHECK HEAT INSULATOR FOR DAMAGE**
5. **CHECK FOR ADEQUATE CLEARANCE BETWEEN CATALYTIC CONVERTER AND HEAT INSULATOR**