

EMISSION CONTROL SYSTEM

EC04H-01

PURPOSE

The emission control systems are installed to reduce the amount of HC, CO and NO_x exhausted from the engine ((3) and (4)), to prevent the atmospheric release of blow-by gas-containing HC (1) and evaporated fuel containing HC being released from the fuel tank (2).

The function of each system is shown in the following table:

System	Abbreviation	Function
(1) Positive Crankcase Ventilation	PCV	Reduces HC
(2) Evaporative Emission Control	EVAP	Reduces evaporated HC
(3) Three-Way Catalytic Converter	TWC	Reduces HC, CO and NO _x
(4) Sequential Multiport Fuel Injection*	SFI	Injects a precisely timed, optimum amount of fuel for reduced exhaust emissions

Remark: * For inspection and repair of the SFI system, refer to the SF section in this manual.

PARTS LAYOUT AND SCHEMATIC DRAWING LOCATION

EC04D-01

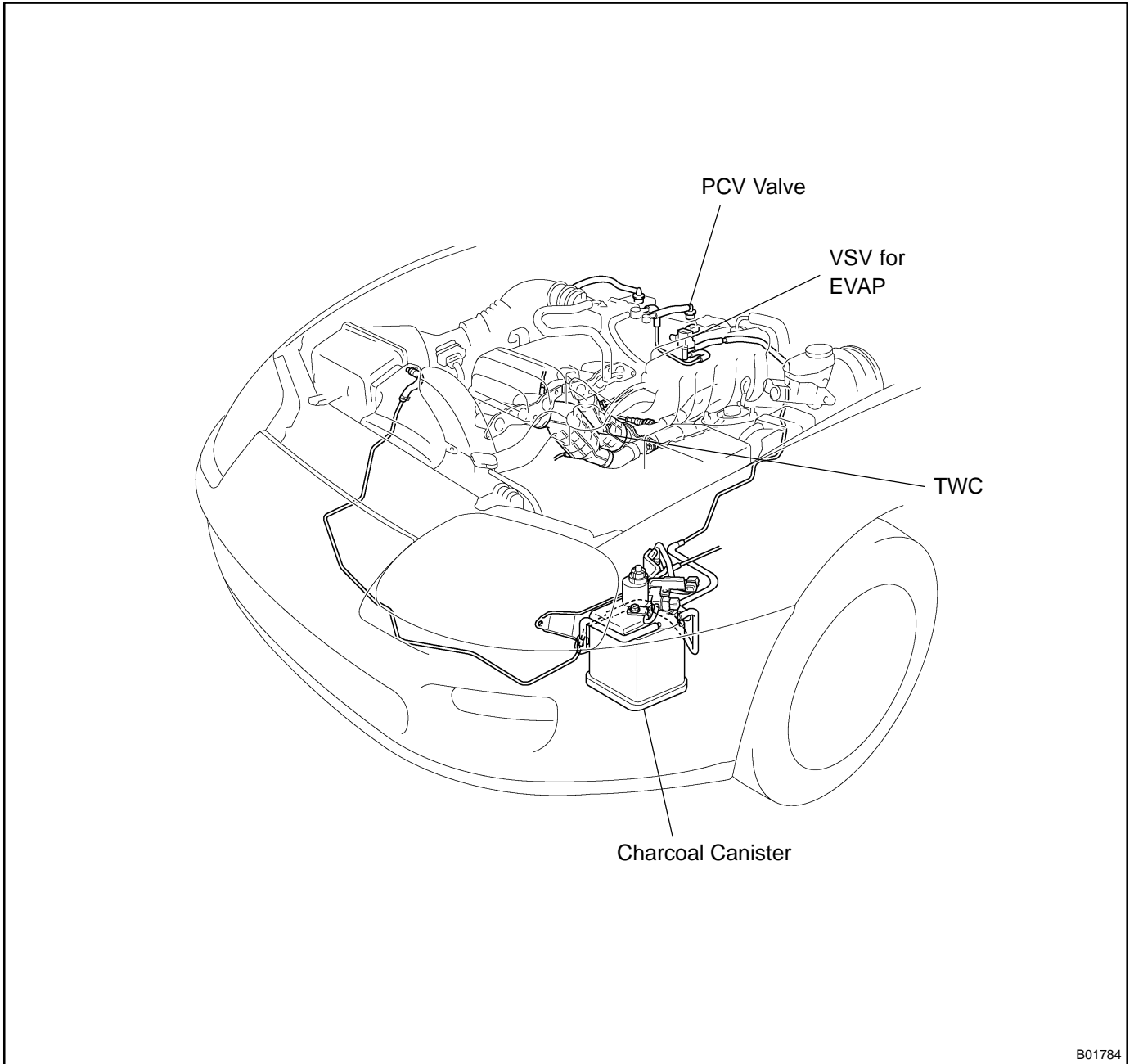

B01784

DRAWING

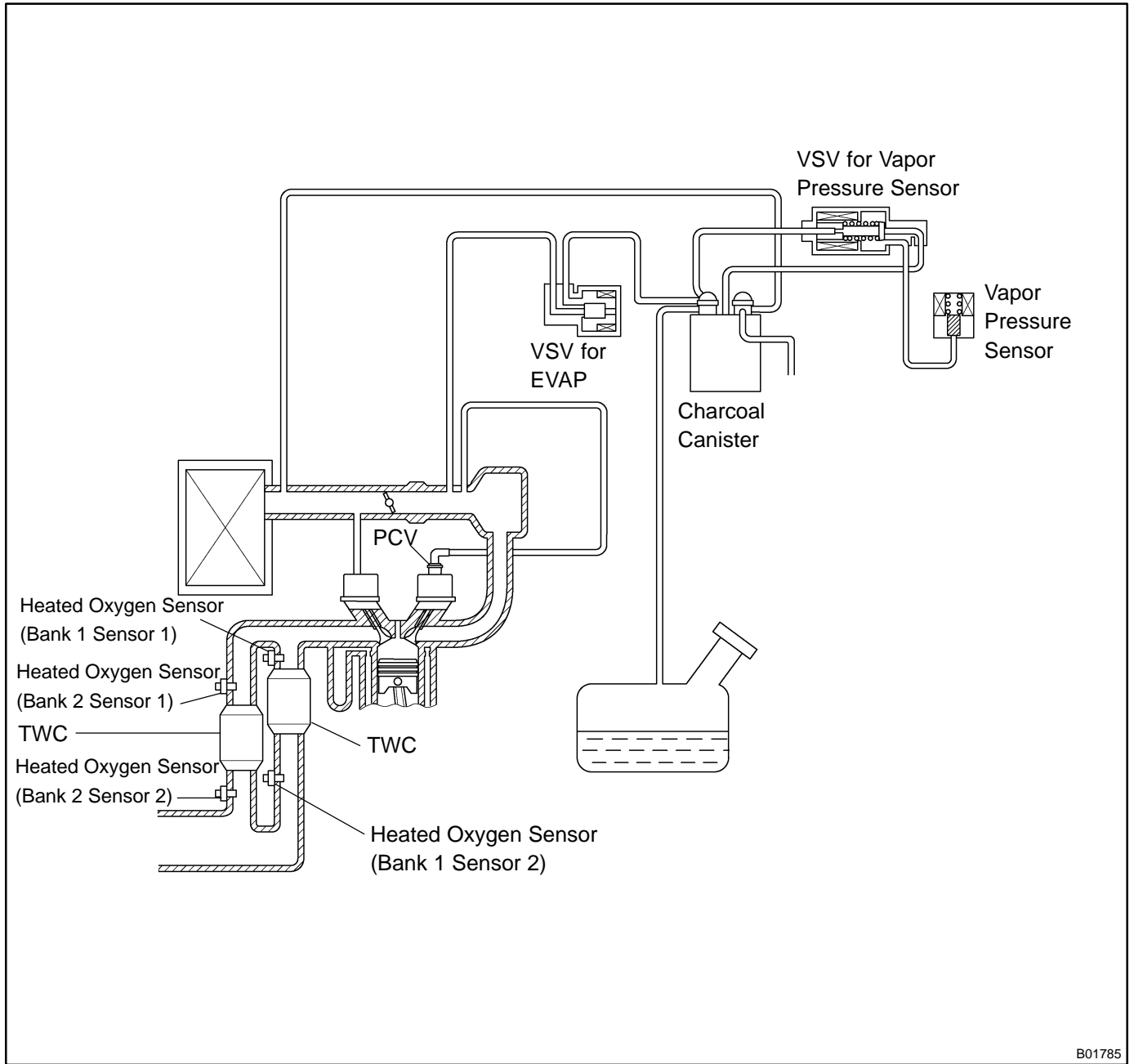

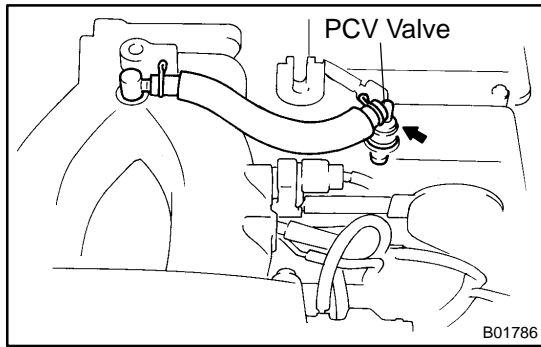

POSITIVE CRANKCASE VENTILATION (PCV) SYSTEM INSPECTION

EC04F-01

1. REMOVE PCV VALVE

- (a) Disconnect the PCV hose from the PCV valve.
- (b) Remove the PCV valve.

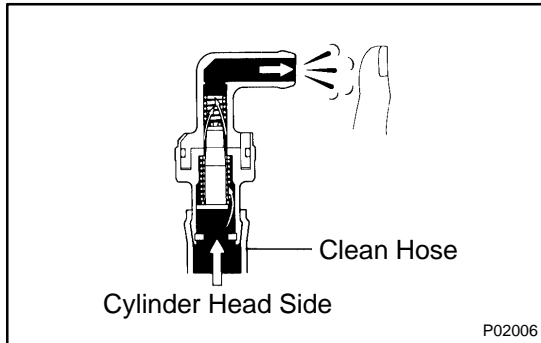

2. INSTALL CLEAN HOSE TO PCV VALVE

3. INSPECT PCV VALVE OPERATION

- (a) Blow air into the cylinder head side, and check that air passes through easily.

CAUTION:

- ◆ Do not suck air through the valve.
- ◆ Petroleum substances inside the valve are harmful.

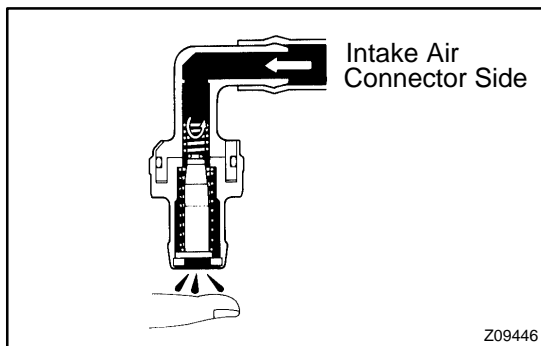

- (b) Blow air into the intake air connector side, and check that air passes through with difficulty.

If operation is not as specified, replace the PCV valve.

4. REMOVE CLEAN HOSE FROM PCV VALVE

5. REINSTALL PCV VALVE

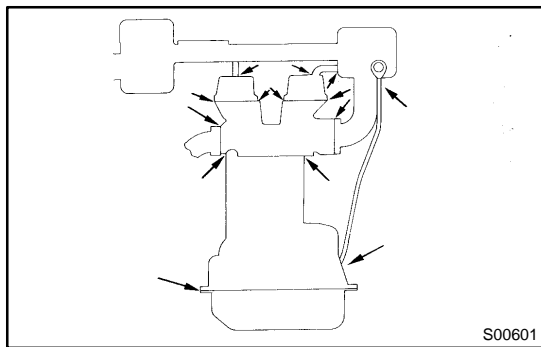

6. VISUALLY INSPECT HOSE, CONNECTIONS AND GASKETS

Check for cracks, leaks or damage.

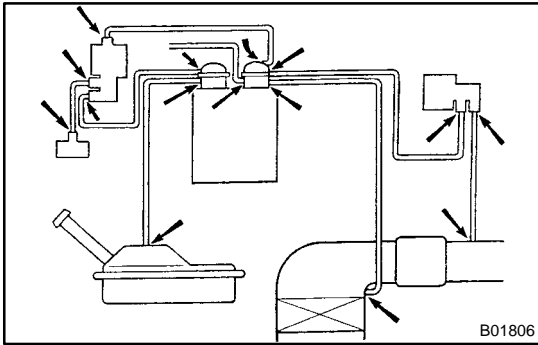

EVAPORATIVE EMISSION (EVAP) CONTROL SYSTEM INSPECTION

EC04G-01

1. VISUALLY INSPECT LINES AND CONNECTIONS

Look for loose connections, sharp bends or damage.

2. VISUALLY INSPECT FUEL TANK

Look for deformation, cracks or fuel leakage.

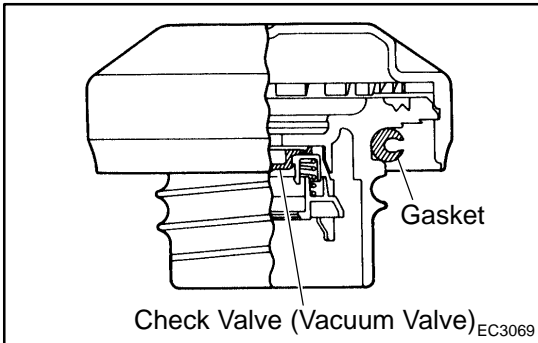

3. VISUALLY INSPECT FUEL TANK CAP

Check if the cap and/or gasket are deformed or damaged.

If necessary, repair or replace the cap.

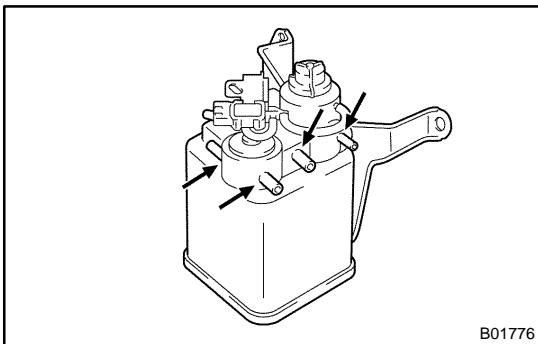

4. REMOVE CHARCOAL CANISTER

5. VISUALLY INSPECT CHARCOAL CANISTER

Look for cracks or damage.

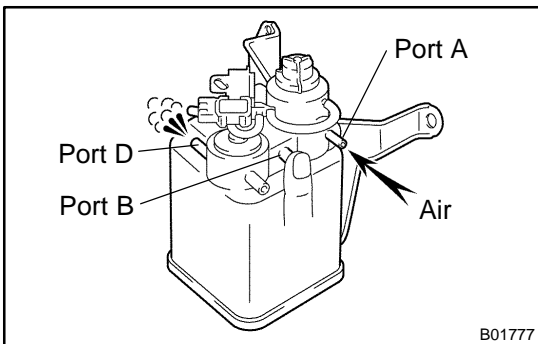

6. CHECK FOR CLOGGED FILTER, AND STUCK CHECK VALVE AND DIAPHRAGM

(a) While holding port B closed, blow air (1.76 kPa (18 gf/cm², 0.26 psi)) into port A and check that air flows from port D.

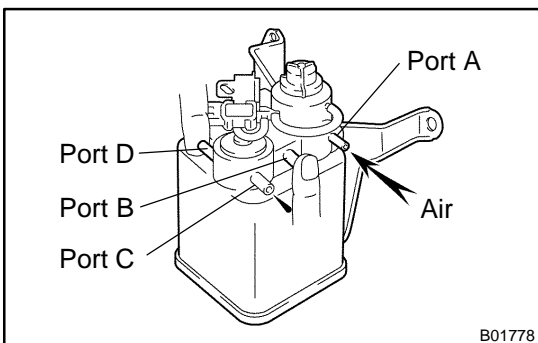

(b) While holding port B and port D closed, blow air (1.76 kPa (18 gf/cm², 0.26 psi)) into port A and check that air does not flow from port C.

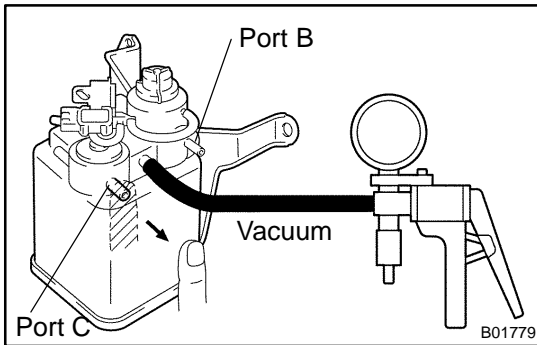

- (c) Apply vacuum (3.43 kPa (26 mmHg, 1.01 in.Hg)) to port B, check that the vacuum does not decrease when port C is closed, and check that the vacuum decreases when port C is released.

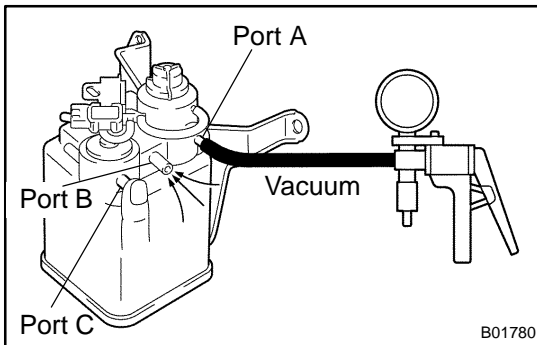

- (d) While holding port C closed, apply vacuum (0.98 kPa (7 mmHg, 0.29 in.Hg)) to port A and check that air flows into port B.

If a problem is found, replace the charcoal canister.

7. **REINSTALL CHARCOAL CANISTER**
8. **INSPECT VSV FOR EVAP**
(See page [SF-50](#))
9. **INSPECT VSV FOR VAPOR PRESSURE SENSOR**
(See page [SF-54](#))
10. **INSPECT VAPOR PRESSURE SENSOR**
(See page [SF-57](#))

THREE-WAY CATALYTIC CONVERTER (TWC) SYSTEM COMPONENTS

EC04A-01

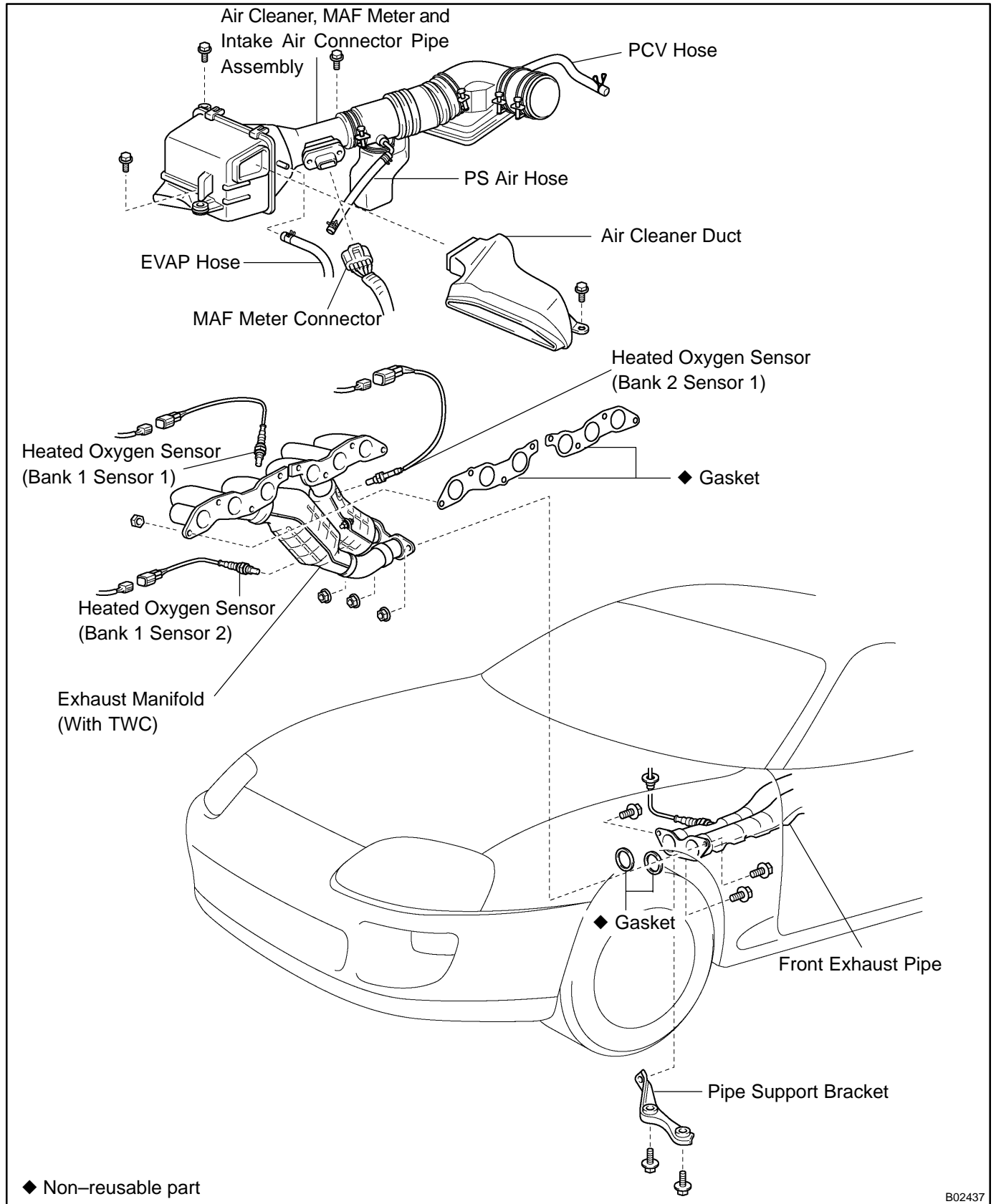

B02437

INSPECTION

1. CHECK CONNECTIONS FOR LOOSENESS OR DAMAGE
2. CHECK CLAMPS FOR WEAKNESS, CRACKS OR DAMAGE
3. CHECK FOR DENTS OR DAMAGE

If any part of protector is damaged or dented to the extent that it contacts the TWC, repair or replace it.

4. CHECK HEAT INSULATOR FOR DAMAGE
5. CHECK FOR ADEQUATE CLEARANCE BETWEEN TWC AND HEAT INSULATOR

REPLACEMENT

1. REMOVE AIR CLEANER DUCT
2. REMOVE AIR CLEANER, MAF METER AND INTAKE AIR CONNECTOR PIPE ASSEMBLY
(See page [EM-58](#))
3. DISCONNECT HEATED OXYGEN SENSORS FROM EXHAUST MANIFOLD
 - (a) Disconnect the 3 oxygen sensor connectors and clamps.
 - (b) Disconnect the 2 oxygen sensors from the exhaust manifold.
4. DISCONNECT FRONT EXHAUST PIPE FROM EXHAUST MANIFOLD (See page [EM-31](#))
5. REMOVE EXHAUST MANIFOLD (WITH TWC)
 - (a) Using a 14 mm deep socket wrench, remove the 8 nuts, exhaust manifold and 2 gaskets.
 - (b) Remove the heated oxygen sensor (bank 2 sensor 1) from the exhaust manifold.
6. RECONNECT HEATED OXYGEN SENSORS TO EXHAUST MANIFOLD
 - (a) Install the 3 oxygen sensors to the exhaust manifold.
Torque: 44 N·m (450 kgf·cm, 33 ft·lbf)
7. REINSTALL EXHAUST MANIFOLD (WITH TWC)
 - (a) Install the 2 new gaskets to the cylinder head.
 - (b) Using a 14 mm deep socket wrench, install the exhaust manifold with the 8 nuts. Uniformly tighten the nuts in several passes.
Torque: 40 N·m (400 kgf·cm, 30 ft·lbf)
8. RECONNECT 3 HEATED OXYGEN SENSOR CONNECTORS AND CLAMPS
9. RECONNECT FRONT EXHAUST PIPE TO EXHAUST MANIFOLD (See page [EM-49](#))
10. REINSTALL AIR CLEANER, MAF METER AND INTAKE AIR CONNECTOR PIPE ASSEMBLY
(See page [EM-63](#))
11. REINSTALL AIR CLEANER DUCT

